

Intelligent VRF

FULL-DC INVERTER CENTRAL
AIR CONDITIONING SYSTEMS



6 Powerful cooling & heating

- DC inverter compressor*
- Double C high efficiency condenser
- DC inverter fan motor
- High efficiency axial fan
- 36°C Three-stage supercooling technology*
- Air-cooled & refrigeration-cooled technology
- Intelligent inverter technology

14 High efficient energy-saving & environmental friendly

- APF up to 5.5
- IPLV up to 10.0
- ODU standby mode
- "2-1"loop design
- Stepless inverter technology
- RoHS certification
- High energy-efficient compressor
- R410A refrigerant
- Variable evaporating /condensing temperature adjustment technology

20 Comfortable & healthy environment

- Extreme fast cooling and heating
- Constant temperature
- Silent-mode
- Healthy air clean strainer
- Fresh air
- Comfortable soft wind
- Intelligent defrost technology

26 Intelligent-operation & maintenance control

- Non-polar CAN bus communication technology
- Multiple control solutions
- NØRDIS CAC management system
- AHU connection kit
- BMS gateways

34 Stable & reliable performance

- Inverter module cooling protection technology
- Six levels oil return technology
- High precision refrigerant control technology
- - 25 °C ~ 56 °C Ultra wide operating temperature range
- Pressure self-regulating technology
- Triple backup function
- Rotation function
- Multiple protections

44 Convenient Installation and Maintenance

- 15 basic modules, satisfy all kind of requirement
- Big-capacity module design
- Super long refrigerant pipeline design
- Auto-refrigerant detecting and auto-charging function
- Highest static pressure for outdoor unit
- Convenient for the transportation
- Auto-addressing function
- ODU without oil balance pipe, compact design
- Emergency power-off function
- Commissioning software

50 ODU lineup & parameters

54 MINI VRF

60 IDU lineup & parameters

- One-way cassette
- Two-way cassette
- Eight-way cassette
- DC series slim duct
- Medium static pressure duct
- High static pressure duct
- Wall mounted
- Ceiling & floor
- Fresh air processing

74 Installation options

The Next Level of Climate Control.

 **NØRDIS** NV6 Full DC Inverter Intelligent VRF



Powerful



High Efficiency



Comfortable

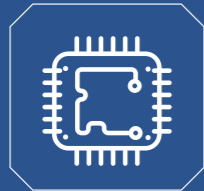

Intelligent



Stable



Convenient





POWERFUL COOLING AND HEATING

Full DC Inverter VRF system, use international famous compressor, DC motor, high-precision EXV and so on, thanks to all these high-technology, equipment has the best cooling and heating performance.



DC inverter
compressor*



DC inverter
fan motor



36°C Three-stage
supercooling technology*



Intelligent inverter technology



Double C
high efficiency condenser



High efficiency axial fan



Air-cooled & refrigerant-cooled
technology for main control board

* Note: Applicable to partial models



1.1 High-efficiency scroll DC inverter compressor with EVI*

- Using new asymmetric scroll profile, reduce leakage loss, reduce ineffective suction overheating, more suitable for APF conditions, improving compressor efficiency.

① Optimized asymmetric vortex line

Using new asymmetric scroll profile, reduce leakage loss, reduce ineffective suction overheating, more suitable for APF conditions, improving compressor efficiency.

② Non-contact oil film seal

Axial and radial compression chamber adopts non-contact seal, relying on lubricating oil to form oil film seal, reduce friction, improving efficiency and reliability.

③ Power terminal cover design

More stable installation, higher security, higher protection level.

④ Centralized winding motor

The coil height of the concentrated coil motor is reduced, the copper loss is reduced, and the middle and low speed zone is more efficient, which is more suitable for APF conditions.

⑤ High speed characteristics

Speed range of 10-140Rps, wider capacity range.

⑥ Internal oil circulation structure

Internal circulation of lubricating oil, reduce overheating loss, reduce oil injection rate, improving efficiency and reliability.

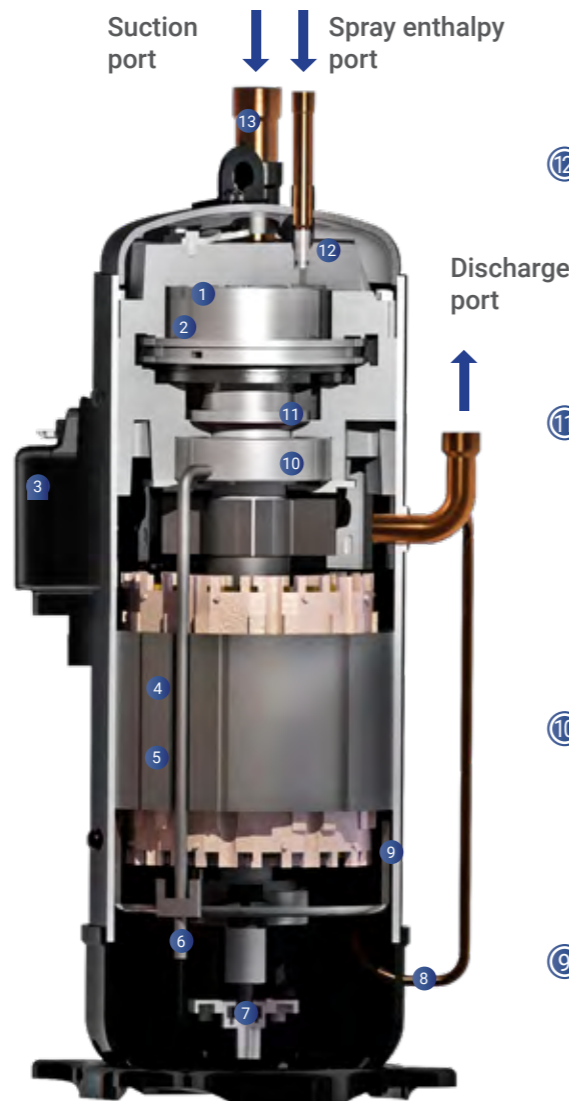

⑬ Direct suction

Small suction preheating, high volume efficiency.

⑫ Pressure relief valve structure

Improving energy efficiency of part load, adapt to variable pressure ratio working conditions, improving compressor performance.

⑪ Intermediate pressure servo mechanism

Adjust the intermediate pressure dynamically according to the operating pressure, realizing the axial flexibility, optimizing the dynamic fixed scroll gear, improving the product performance.

⑩ High reliability bearings

The bearing group with cylindrical bearing and self-aligning ball bearing, improving the reliability of compressor.

⑨ High pressure cavity structure

Large exhaust buffer volume can reduce airflow noise and vibration during operation.

⑧ Dynamic oil equilibrium structure

The oil balance tube realizes the dynamic balance of the oil quantity of the parallel compressor to ensure the reliability of the parallel operation of multiple compressors.

⑦ Positive displacement gear pump

Positive displacement gear oil pump to ensure high and low frequency can meet the necessary oil supply, improve the reliability of the compressor.

* Note: Applicable to some models

Double enthalpy of cooling and heating *

- Through the double enthalpy increasing technology of refrigeration and heating, 56°C high temperature strong cooling and -30°C low temperature strong heating are effectively realized. During refrigeration, when refrigerant enters indoor unit after long piping, the undercooling degree is low, and it is easy to produce refrigerant noise through the electronic expansion valve throttling. By opening the auxiliary valve and the plate to change the branch road, the refrigerant circulation quantity is increased, the system undercooling degree is improved, and the refrigerant flow sound is effectively suppressed. During heating, the outdoor environment temperature is lower, refrigerant low density, gas compressor suction side back to reduce, reduce the refrigerant circulation and heating performance. By spraying branch added gaseous refrigerant compressor middle pressure, thus increasing overall system refrigerant circulation, effectively improve the low temperature heating ability, realize stable run to 30°C, 15°C low temperature heat up 30%.

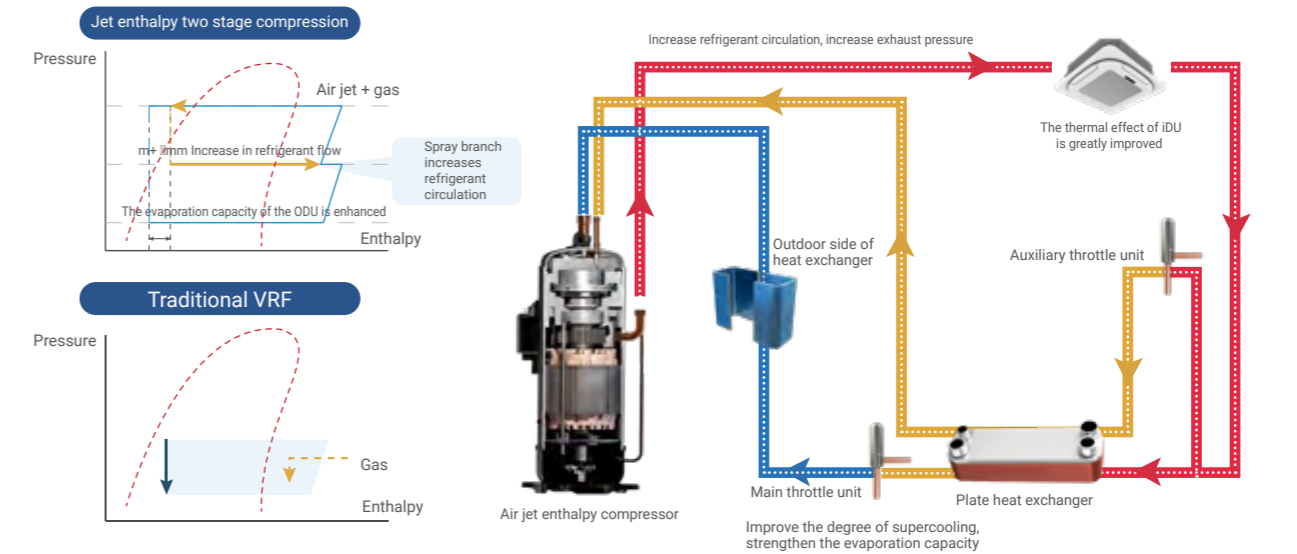

Asymmetric vortices

- In view of the high pressure characteristics of R410A refrigerant, the compressor strengthens the bearing structure and adopts the design of asymmetric scroll disk, which has the following advantages over the symmetrical scroll disk:

- ✓ Reduce refrigerant leakage and improve efficiency;
- ✓ Two adjacent chambers have small pressure difference, small vibration and more mute;
- ✓ Prevent over compression, prolong the service life of the compressor.

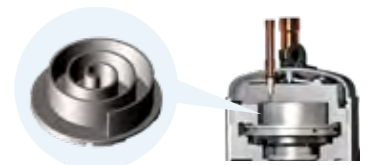

Motor rotor with neodymium magnetic material

- Neodymium, an artificial permanent magnet, is one of the strongest magnetic materials to date. The magnetic force of neodymium magnet is 10 times that of common ferrite magnet. Under the same volume, the electromagnetic field intensity is stronger, the starting torque is larger, and the operation efficiency is higher.



Large-displacement and ultra-wideband operation technology

- Displacement up to 98cc, far more than the ordinary compressor (displacement < 80cc), the operation frequency of 10RPs-140rps, far more than the ordinary compressor 20RPs-100rps, strong power, realizing fast refrigeration and heating.

* Note: Applicable to some models

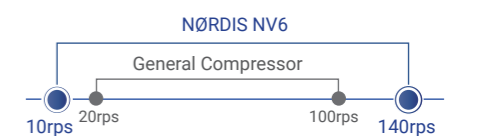

1.2 Double 'C' type heat exchanger

- Double C-type compact super-large area heat exchanger, makes the heat exchange area larger, reduces the pressure loss of the heat exchanger, improves the efficiency of heat exchanger, and has higher efficiency when running under heavy load.

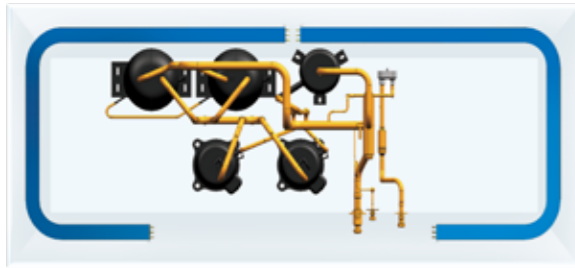

Note: The heat exchanger structure and fan diameter are determined by the specific model.

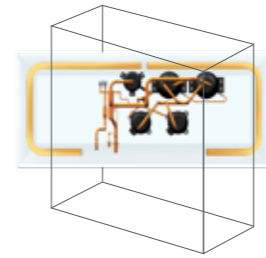

Double C Compact Large Area Heat Exchanger Ordinary Heat Exchanger

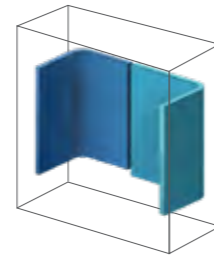

Common heat exchanger

- The new structural design further improves the matching of system partial load and reduces the floor area of the whole machine.

↓ **36HP occupies only 1.6055 m², which is 21.4% less than the previous generation**



- Heat exchanger adopts the perfect combination of multi-coated hydrophilic aluminum foil heat exchange fins and high-efficiency internally threaded heat exchange copper tubes, which greatly improves the heat exchange efficiency and enhances the corrosion resistance and oxidation resistance of the heat exchanger.

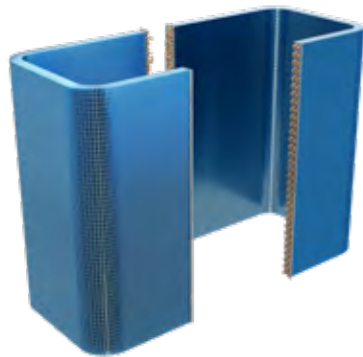

Φ7 Heat Exchange Copper Tube

Multiple rows of small-diameter heat exchange tubes, the tube spacing is smaller, and the number of copper tubes used in the same length is more, which effectively increases the heat exchange area of the heat exchanger and improves the heat exchange efficiency of the heat exchanger

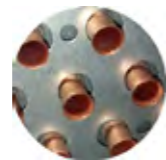

Internally threaded copper tubes

The inner surface of the internally threaded copper pipe is designed with a groove, which increases the contact area with the refrigerant, so that the heat exchange performance and thermal conductivity of the heat exchanger are better

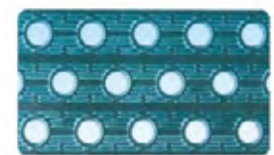

Hydrophilic aluminum fin

The condensed water will spread out quickly on the hydrophilic aluminum foil without condensing into water droplets, increasing the heat exchange area, speeding up the cooling and heating speed, and effectively avoiding the noise caused by the condensed water obstructing the air flow



- Lubricating layer**
Destroy the surface tension of water droplets, accelerate the downstream speed of condensed water or defrosting water, and improve the air conditioning capacity
- Hydrophilic coating**
Ensure that the air conditioner is not easy to form frost when heating
- Corrosion resistant coating**
Slow down the corrosion of corrosive gas to the heat exchanger
- fins**

1.3 High voltage (concentrated coil) DC motor

- The outdoor unit fan motor adopts a high-voltage centralized winding DC motor, which has a more stable and reliable output, effectively reduces losses and improves operating efficiency.

Concentrated coil motor

Reduced coil height, reduced copper loss, higher efficiency in low and medium speed zones, and higher APF energy efficiency.

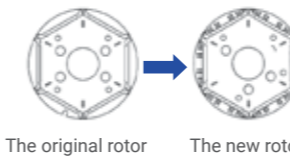

The original rotor The new rotor

Neodymium magneto rotor
Improve motor efficiency
And reduce motor noise



1.4 750 mm Large size axial flow fan

- The outdoor unit fan adopts φ750mm super-size wind wheel, compared with ordinary air conditioner φ540mm dual fans, it has sufficient air volume, higher heat exchange efficiency and lower noise.

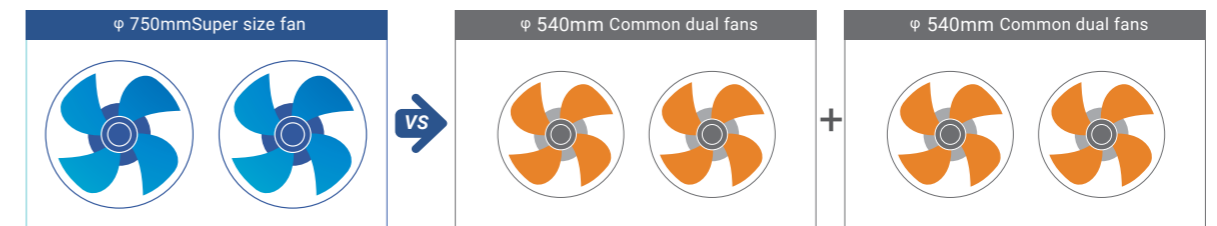

- The fan is steplessly adjusted according to environmental conditions and air-conditioning load conditions, and is matched with the compressor's stepless frequency conversion technology, so that the system runs more stable and reliable.

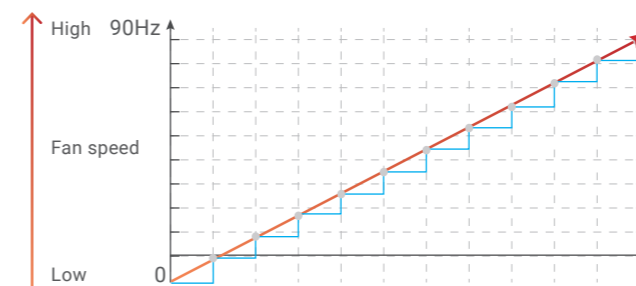

Stepless speed regulation Average speed

- Accurately adjust the refrigerant pressure to improve the reliability of the unit;
- The motor speed is adjusted quickly to better adapt to the rapid changes in air-conditioning load.

1.5 3-Stage sub-cooling technology to achieve 36°C sub-cooling

- Optimize the design of heat exchanger and flow path to improve heat exchange effect. The 3-stage sub-cooling cycle increases the refrigeration capacity of the unit mass refrigerant, reduces the flow resistance of the refrigerant in the pipe; the electronic expansion valve has more precise control and more stable operation.

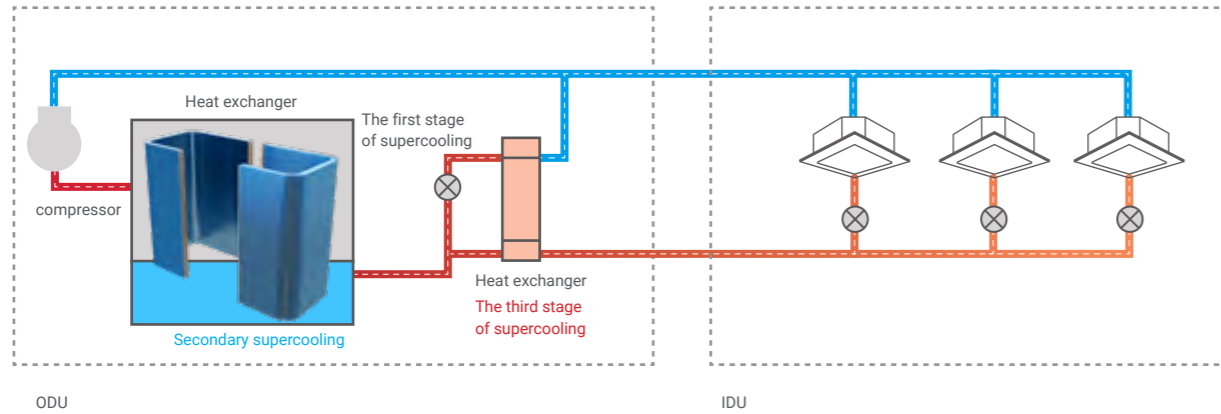

- When the outdoor environment is 35°C, the refrigerant is cooled to 37.1°C, and the high-efficiency heat exchange with a temperature difference of only 2.1°C can achieve 11.2°C subcooled after one or two stage of subcooling.

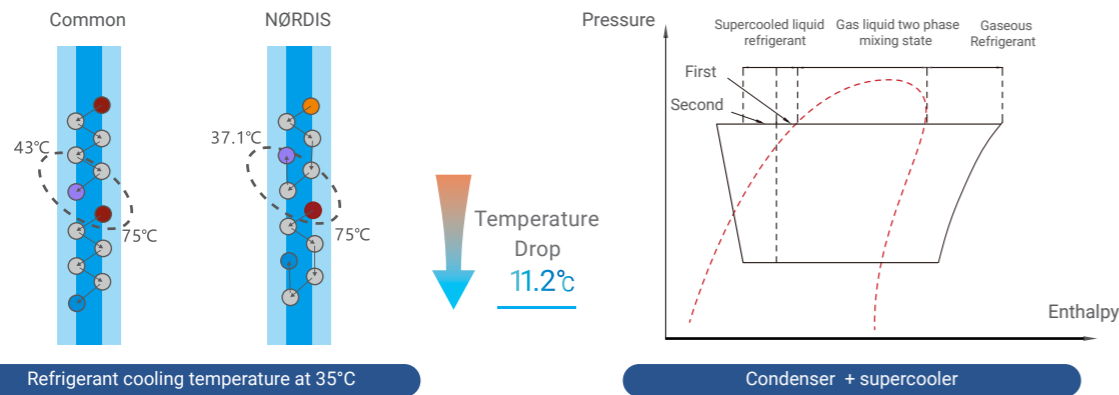

- The high-efficiency plate heat exchanger is selected as the secondary subcooler to further cool the refrigerant at 37.1°C to achieve subcooling at 26°C, further reducing the flow resistance of the refrigerant, which is conducive to improving the energy efficiency of the system and increasing the length of piping, while improving the cooling and heating effects And system reliability.

* Note: Applicable to some models



Plate heat exchanger

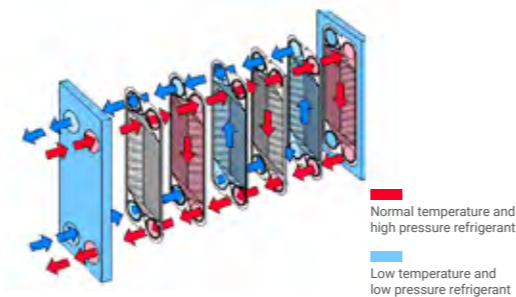

Schematic diagram of plate heat exchanger circulation

1.6 Intelligent Inverter

- The unit uses multiple sets of high-precision, high-efficiency and high-reliability intelligent inverters to control the compressor and fan motors, making the control more flexible, efficient and intelligent.

Intelligent inverter

- It can effectively reduce high-order harmonic components, motor vibration, torque fluctuation and noise;
- It can ensure the smooth start of the compressor, reduce the starting current of the compressor, and reduce the impact on the power grid; increase the operating frequency range of the compressor;
- Ultra-wide voltage operating range, stable operation within the three-phase 243V-460V voltage range;
- It has multiple protection functions such as undervoltage, overvoltage, overcurrent, and overtemperature to ensure the efficient and reliable operation of the system.



1.7 Surrounding refrigerant cooling technology

- The outdoor unit's inverter module is cooled by refrigerant to ensure that the inverter module can be effectively cooled in a high-temperature environment, reduce the working temperature of the frequency conversion module, and improve the reliability and service life of the electronic control system. It also prevents poor heat dissipation under extreme conditions, such as due to the periodic stop of the fan.

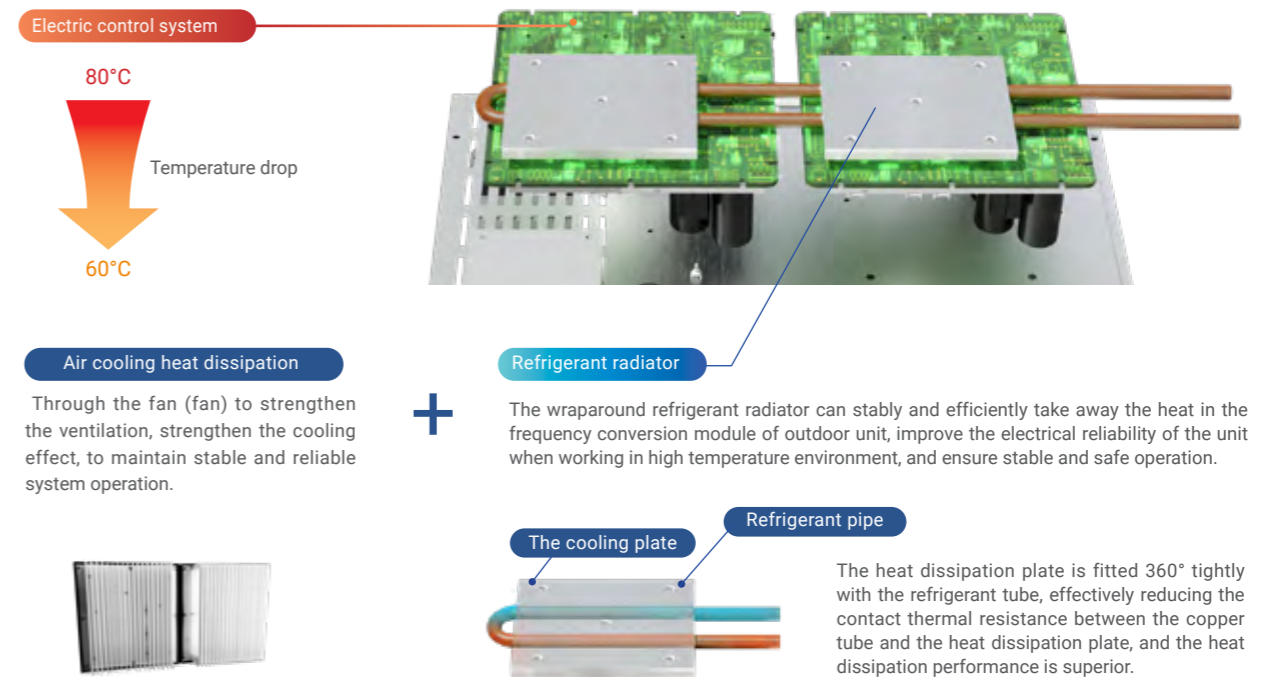



HIGH EFFICIENT ENERGY-SAVING AND ENVIRONMENTAL FRIENDLY

The global climate is facing severe challenges, in order to achieve the "dual carbon" goal, it has become an urgent issue for enterprises to control carbon emissions effectively, improve energy efficiency and reduce energy consumption. NØRDIS CAC follows the product design concept of high efficiency, energy saving and low carbon, use high-quality components of efficient refrigeration and leading refrigerating technology, to achieve building air-conditioning systems. Integrate the goal of green, reliable and efficient energy management.



APF
5.5

APF up to 5.5



IPLV
10.0

IPLV 10.0



ODU standby mode



2-1

"2-1" loop design



Stepless inverter technology



RoHS

RoHS certification



High energy-efficient compressor



R410A

R410A refrigerant



Variable evaporating/condensing temperature adjustment technology





2.1 APF up to 5.5

- Far exceeding the national first-level energy efficiency standard
NV6 full DC inverter intelligent VRF product, its annual comprehensive energy efficiency ratio APF is up to 5.5, and all series exceed the new national standard first-level energy efficiency standard.

APF calculation formula

$$APF = \frac{\text{Total cooling season load} + \text{Total heating season load}}{\text{Total power consumption in cooling season} + \text{Total power consumption in heating season}}$$

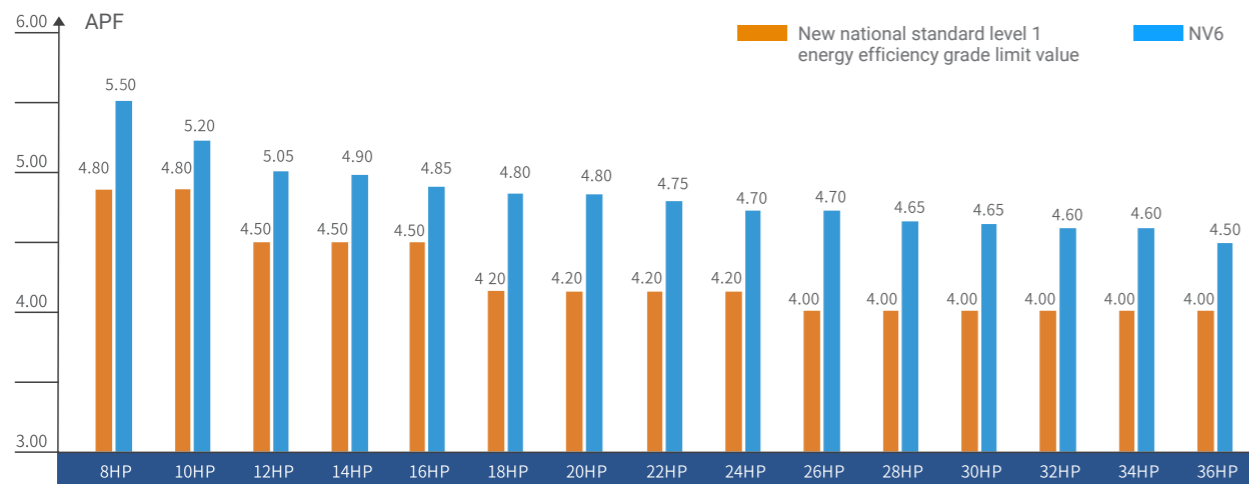

2.2 IPLV(C) up to 10.0

- IPLV(C) up to 10.0, excellent energy saving effect.

IPLV(C) is the refrigerating comprehensive coefficient of performance, which is used to measure the part-load efficiency of VRF air conditioners in the cooling season. Since most of the time, only part of the air conditioner can be used in commercial places, IPLV(C) can reflect the energy-saving performance of central air conditioners in actual operation more accurately.

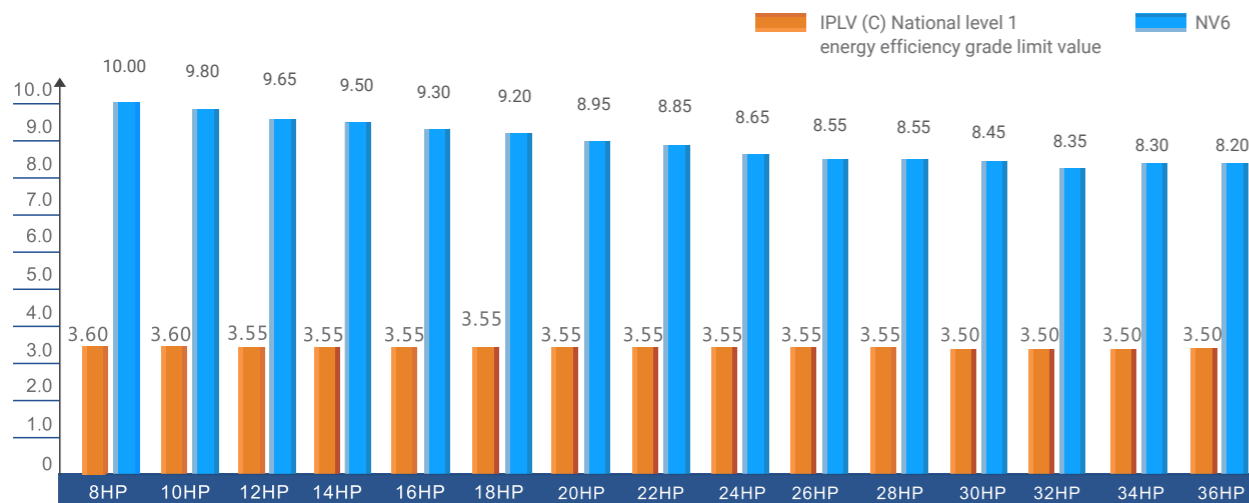

2.3 Authoritative attestation

- The NV6 series full inverter VRF units, through the compressor core frequency conversion technology upgrade, the overall optimization of the refrigeration system and the control system, makes the unit energy-saving performance even better, and has passed the national first-level energy efficiency standard certification.



Certification Bodies' Scheme



Conformite Europeenne

2.4 DC inverter scroll compressor*

- The DC variable frequency compressor adopts an asymmetric scroll structure to effectively reduce the leakage loss of refrigerant gas during suction and inside the compression chamber, to improve the efficiency and reliability of compressor operation.



Optimized asymmetric vortex line

Using new type of asymmetric scroll profile can reduce leakage loss and ineffective suction overheating, which is more suitable for APF conditions and improves compressor efficiency.

Concentrated winding motor

The coil height of the concentrated winding motor is reduced, the copper loss is less the efficiency is higher in the middle and low speed areas, and it is more suitable for APF conditions.

Suction directly

Small suction preheating, high volume efficiency

Intermediate pressure servo mechanism

The intermediate pressure is dynamically adjusted according to the operating pressure to achieve axial flexibility, optimize the orbiting and fixed scroll teeth, and improve product performance.

*Note: EVI compressor is optional

2.5 High efficiency "2-1" refrigerant flow

- Compared with gaseous refrigerant and liquid refrigerant, gas-liquid mixed phase refrigerant has higher heat exchange efficiency. This circuit can not only increase the amount of liquid refrigerant but also increase the flow rate of the refrigerant and increase the heat exchange efficiency.

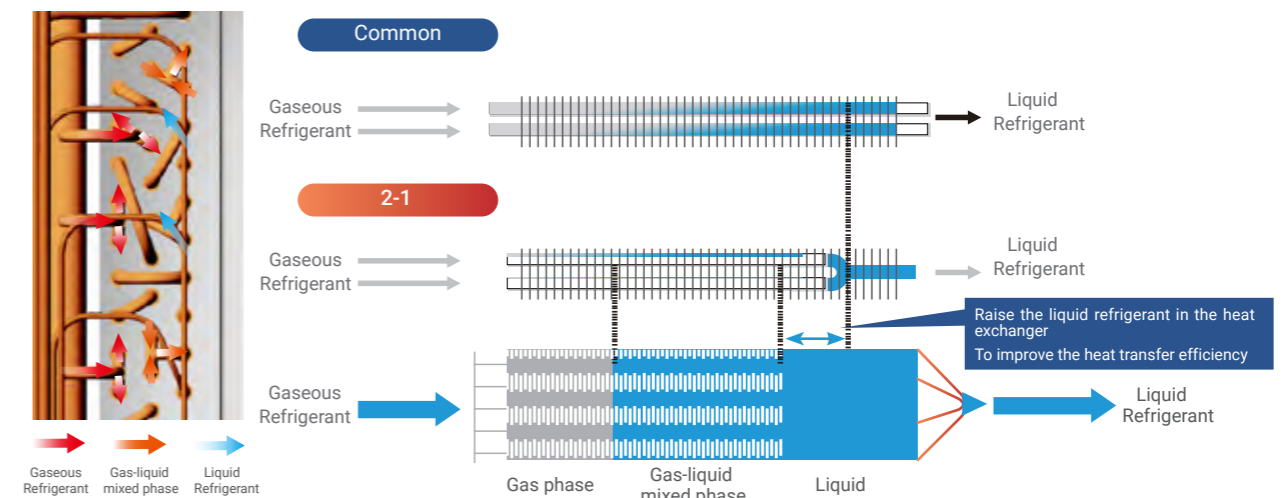



2.6 0~480Hz stepless frequency adjustment

The operating speed of the DC inverter compressor can be adjusted continuously and freely according to the change of the system capacity. The accuracy is higher, the stepless frequency conversion is realized, and the sub-adaptive control technology is combined, and the capacity output is automatically adjusted according to the actual control load to ensure a higher level of accuracy. Smooth change curve to meet higher demands for comfort. NØRDIS's NV6 can only use broadband compressors and powerful inverter control motherboards for multiple connections. The compressors operate at 0-480Hz broadband, which has more capacity and can better cope with various complex and harsh extreme conditions.

The unit has industry-leading EER and Integrated Part Load Value IPLV (C)

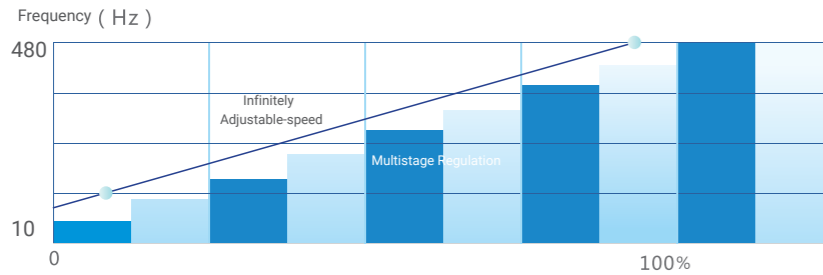

The compressor adopts 180° sine wave vector drive technology, which can obtain an ideal smooth sine wave curve, so that the motor runs smoothly, the electric energy efficiency is higher, and the harsh sound is reduced.

Vector control technology effectively suppresses high magnetic harmonic current and electromagnetic noise, and has passed the national EMC electromagnetic interference test

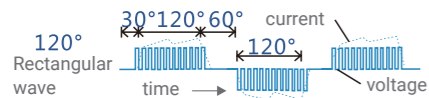
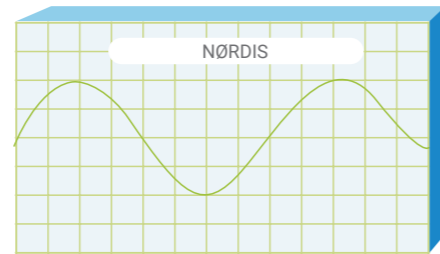
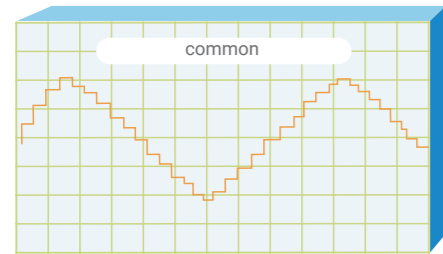

2.7 Four seasons energy-saving mode

Select the automatic energy-saving mode, the system optimizes output according to changes in ambient temperature, realizes automatic control of energy-saving in all seasons, and improves the overall energy efficiency of the unit's all-season operation.

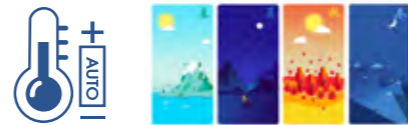

2.8 ODU standby mode

When there is no need for cooling and heating indoors, the control system issues a command to cut off the power supply of the outdoor heating and power devices of the electric control module. The standby power of the outdoor unit is as low, which is low-consumption and energy-saving.



2.9 Variable evaporating/condensing temperature regulation technology

The self-adaptive adjustment of evaporating and condensing temperature can ensure that when the air conditioner is running, the refrigerant flow can be accurately controlled according to the demand, and the evaporating/condensing temperature can be automatically adjusted to reduce temperature fluctuation, to achieve the effect of energy saving and constant temperature.

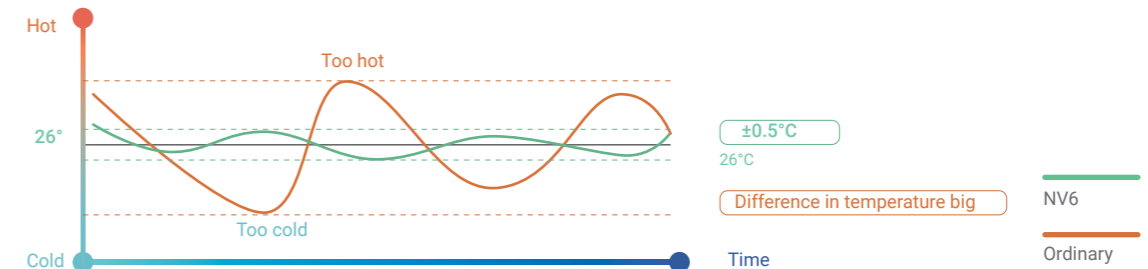

2.10 Multi-priority modes, VIP priority service

The NV6 system can be set with a variety of operating modes, cooling only/heating only/cooling priority/heating priority/VIP priority/first opening priority to prevent mode conflict.



Response only coolong



Respond only heating



Cooling priority



Heating priority



VIP priority

2.11 R410A High-efficiency environmentally friendly refrigerant

R410A is an HFC refrigerant that does not damage the ozone layer. Using R410A can increase the COP and protect the ozone layer. It is an efficient and environmental- friendly refrigerant.

R410A is non-toxic and is a "non-flammable refrigerant".



2.12 RoHS Certification

NV6 full inverter VRF unit is highly efficient and environmentally friendly. Seiko builds global quality and has passed EU RoHS certification.





COMFORTABLE AND HEALTHY ENVIRONMENT

People's demand for a healthy air environment is constantly escalating. The improvement of air quality in buildings is more and more important. NØRDIS intelligent VRF has been seeking technical innovation to provide people with a comfortable and clean, healthy air environment to build people's high-quality life.



Extreme fast cooling and heating



Constant temperature



Silent-mode



Comfortable soft wind



Fresh air



Auto restart function



Intelligent defrost technology





3.1 Fast cooling and heating

- NØRDIS VRF adopts a large-capacity DC inverter compressor which can start the unit quickly and achieve a super cooling and heating capacity output, to provide a comfortable room environment.

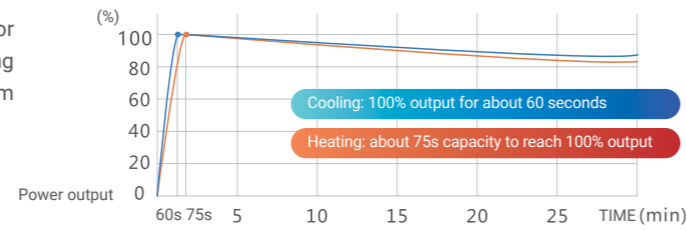

3.2 Constant temperature

- Multiple sensors detect the real time temperature of the system to make sure the indoor temperature fluctuation within $\pm 0.5^{\circ}\text{C}$.

Multi-electronic expansion valves

- The outdoor unit has multiple electronic expansion valves with a control accuracy up to 3000 level, which can adjust the refrigerant circulation and control the compressor overheat accurately to get a precise temperature control.

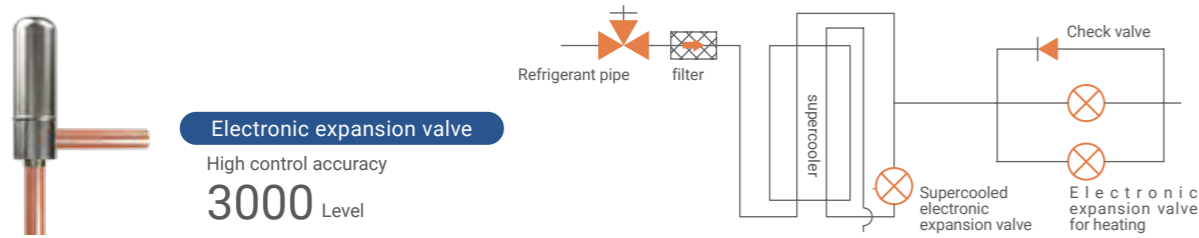

High-precision temperature sensor

- Can detect accurate temperature with precision 0.5°C



Dual pressure sensors

- High precision and sensitivity can detect the temperature fluctuation quickly and accurately.



Refrigerant liquid by-pass technology

- This technology is mainly used to increase the refrigerant flow and improve the cooling effect when the indoor side refrigerant flow is insufficient.

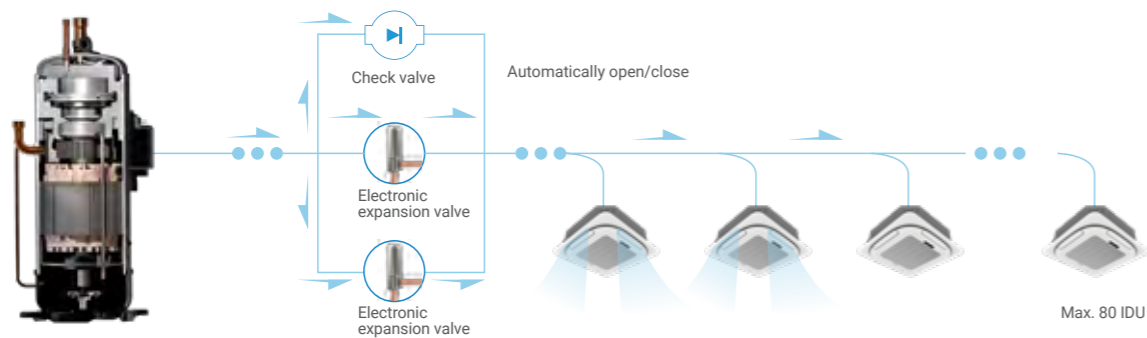

3.3 Multiple silence technology

13 items of silent improvements

The structure of each component is involved in optimized airflow analysis, which can not only operate with low noise, but also ensure the air volume and operation effect of the outdoor unit.

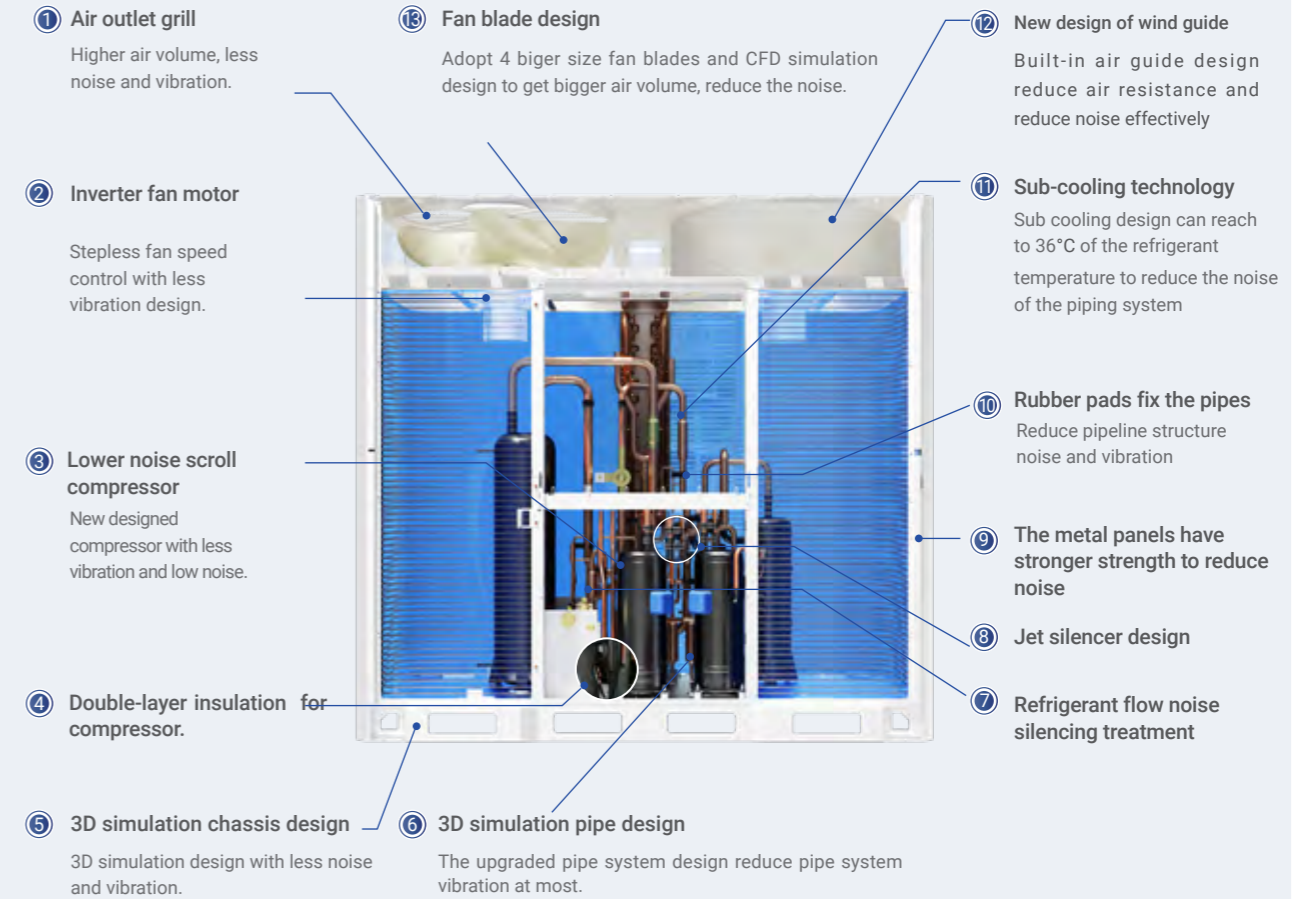

Night silent mode

- The ODU can automatically check the highest ambient temperature and record the time, then to start the silent operation mode after 8 hours, system returns to the normal mode after running for 10 hours. To make the ODU running noise to as low as 45dB(A).

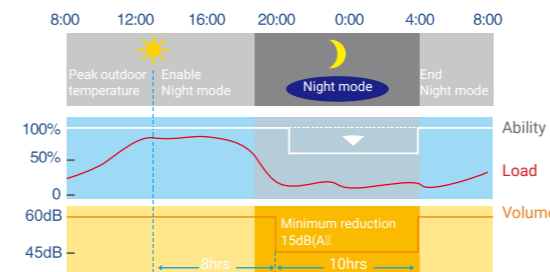

Super silent mode

- In this mode, the running noise of the system will be reduced to be 40dB(A).

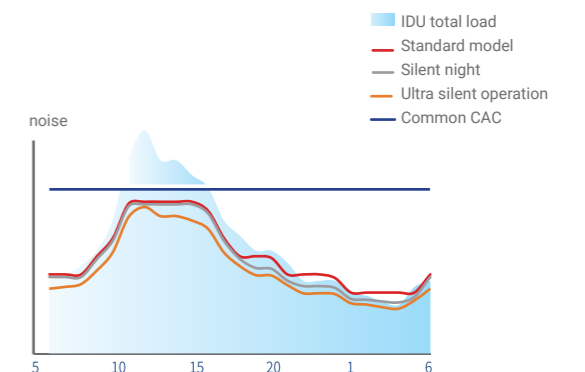



3.4 Fresh air solution

- NØRDIS VRF can supply the multiple fresh air solutions such as fresh air processing units , ERV and air handing units etc.



3.5 Comfortable soft wind panel

- The upgraded panels have a beautiful appearance and provide comfortable air supply .



3.6 Intelligent auto-restart function

- When a sudden power failure occurs, system will automatically store the state of the machine before the power failure. When the machine is restarted, the system will automatically restart with the settings before the power failure (operation mode, set temperature, fan speed, etc).

Note: This function can also start manually

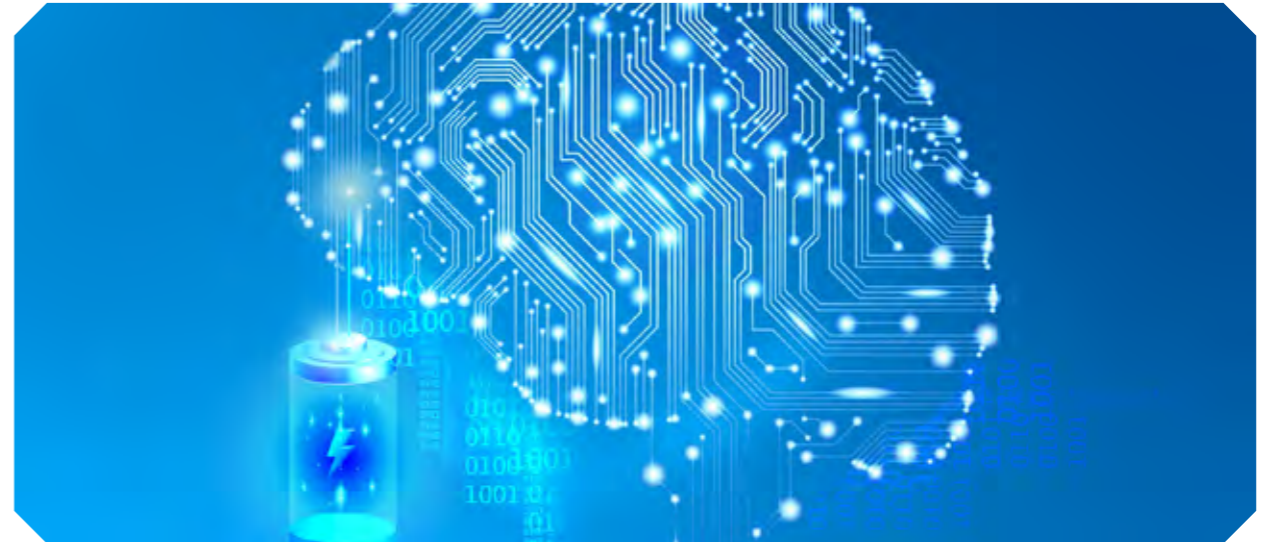

3.7 Intelligent defrost technology

- The system can automatically decide the time to defrost according to the operation data and heating capacity.
- Under high humidity condition, the system will defrost in advance to keep the room comfortable.
- During defrosting, the system will close the indoor to avoid the cold air .

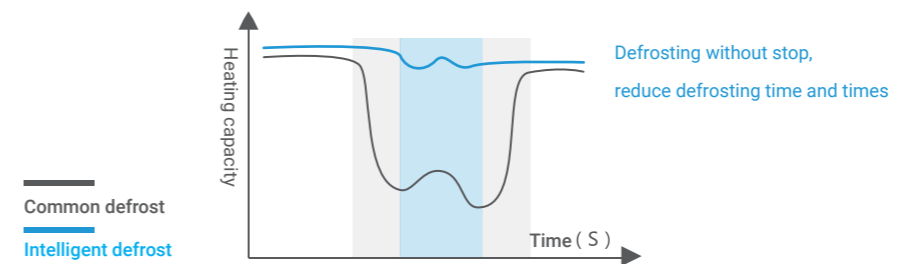
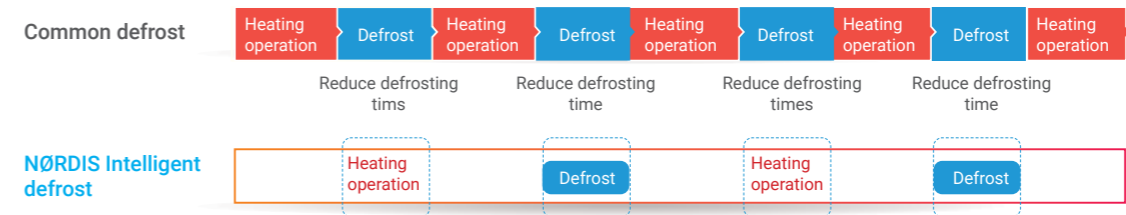

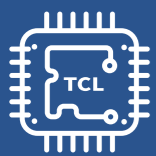

INTELLIGENT - OPERATION AND MAINTENANCE CONTROL

NØRDIS full DC inverter VRF systems can provide the intelligent operation and maintenance functions, which provides an efficient solution for the intelligent operation and maintenance of buildings, It ensures energy-saving and high-efficient operation and intelligent management.



Non-polar CAN bus communication technology



Multiple control solutions



NØRDIS remote intelligent service center



NØRDIS CAC management system



BMS gateways



AHU connection kit





4.1 Intelligent Control

Smart commissioning

- During installation, the system automatically detects the number of indoor and outdoor units, communication link status, and real-time feedback of installation abnormalities, making installation simple and easy.

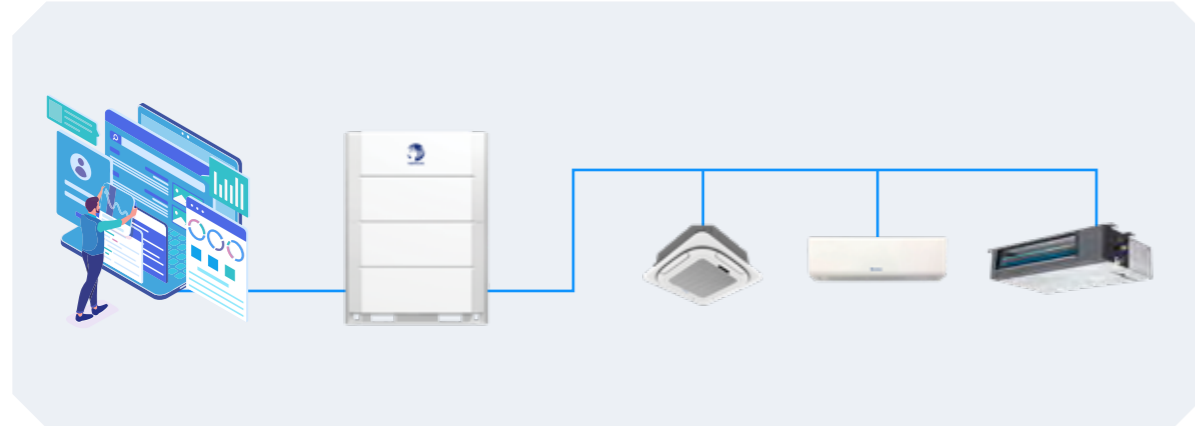

Intelligent detection

- When the equipment is running, the system records the best running status intelligently. And it will adjust the compressor frequency and the step of the EXV for next time automatically.



Smart detection

- During system operation, data will be recorded, abnormalities will be automatically detected and raised.



4.2 Non-polar CAN bus communication technology

- NV6 adopts CAN bus communication technology, which is a communication technology applied in the field of automobile and military industry.

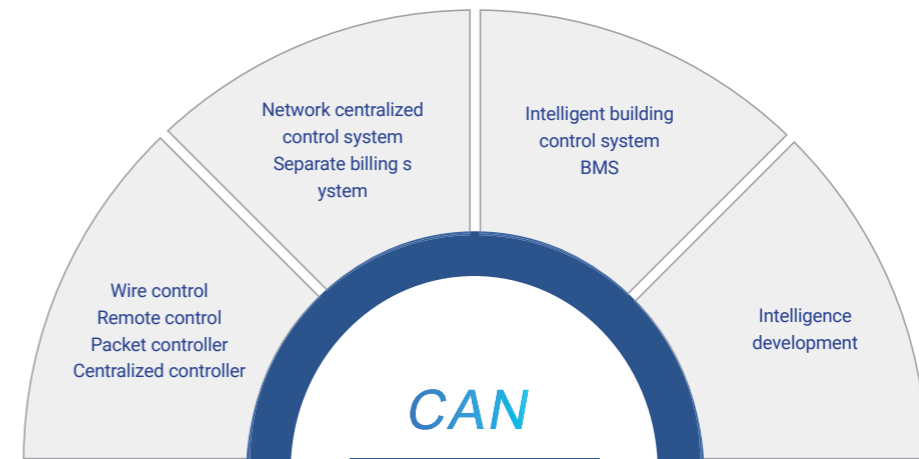

	NV6 VRF(CAN communication)	Other similar products in the industry(RS 485 communication)
Reliability	High reliability and stable network	The reliability is unstable and easy to be paralyzed
Communication efficiency	Up to 100kbs	About 10kbs
Communication distance	About 2000m	About 1000m
Communication line polarity	No polarity, easy to debug	Polarities need to be distinguished for installation
Scalability	Easy to plug and play	To add new device, the software must be changed, and the scalability is poor



4.3 Multiple control solutions

NV6 provides a variety control solutions for customers to choose .

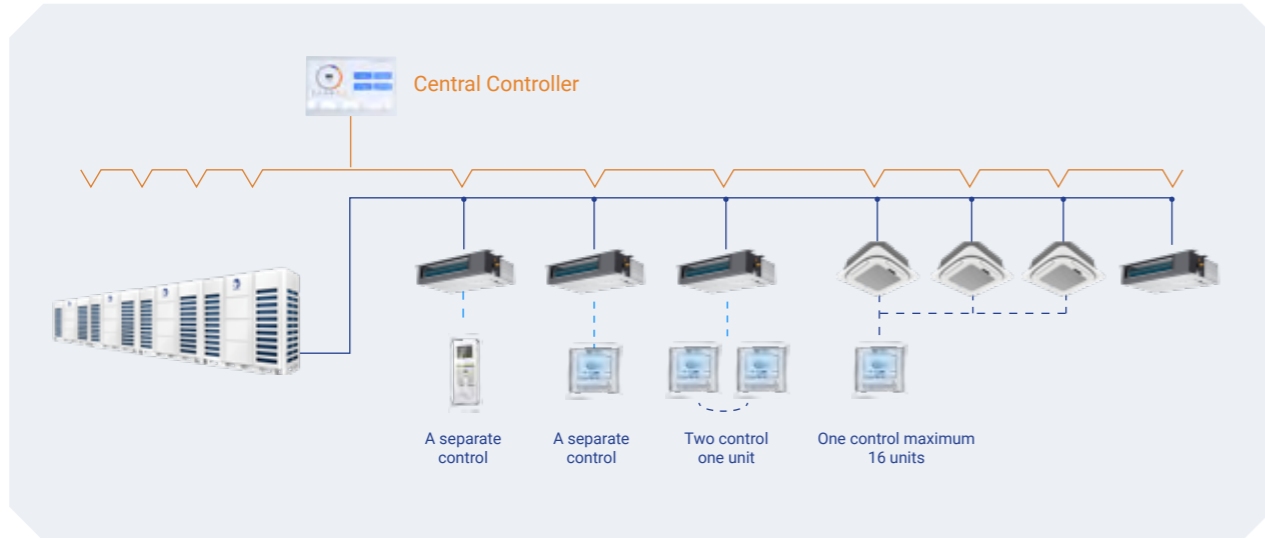

Remote Controller

- Cooling / dehumidification / fan / heating / automatic and other operation settings
- Temperature / fan speed setting
- Sleep/timer/swing/turbo and other functions



Wired Controller

- Cooling / dehumidification / fan / heating / automatic and other operation settings
- Temperature / fan speed setting
- Sleep/timer/swing/turbo and other function settings
- Monitoring function, big LCD screen displays the operation status of the unit
- Remote control signal available



Central Controller

- 7 inches and colorful screen display, beautiful appearance, touch screen, easy operation.
- A variety of combinations, single or multiple machines can be operated simultaneously.
- Up to 16 systems and 180 indoor units can be connected, easy to set indoor units parameters.
- It also has the schedule setting and historical fault query function.

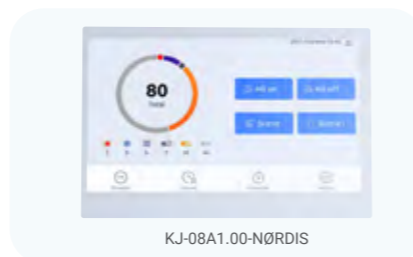

4.4 NØRDIS Management System

NØRDIS VRF system adopts the CAN bus communication technology. It connects indoor units with the computer through a network converter, to provide centralized and smart control of the whole systems.

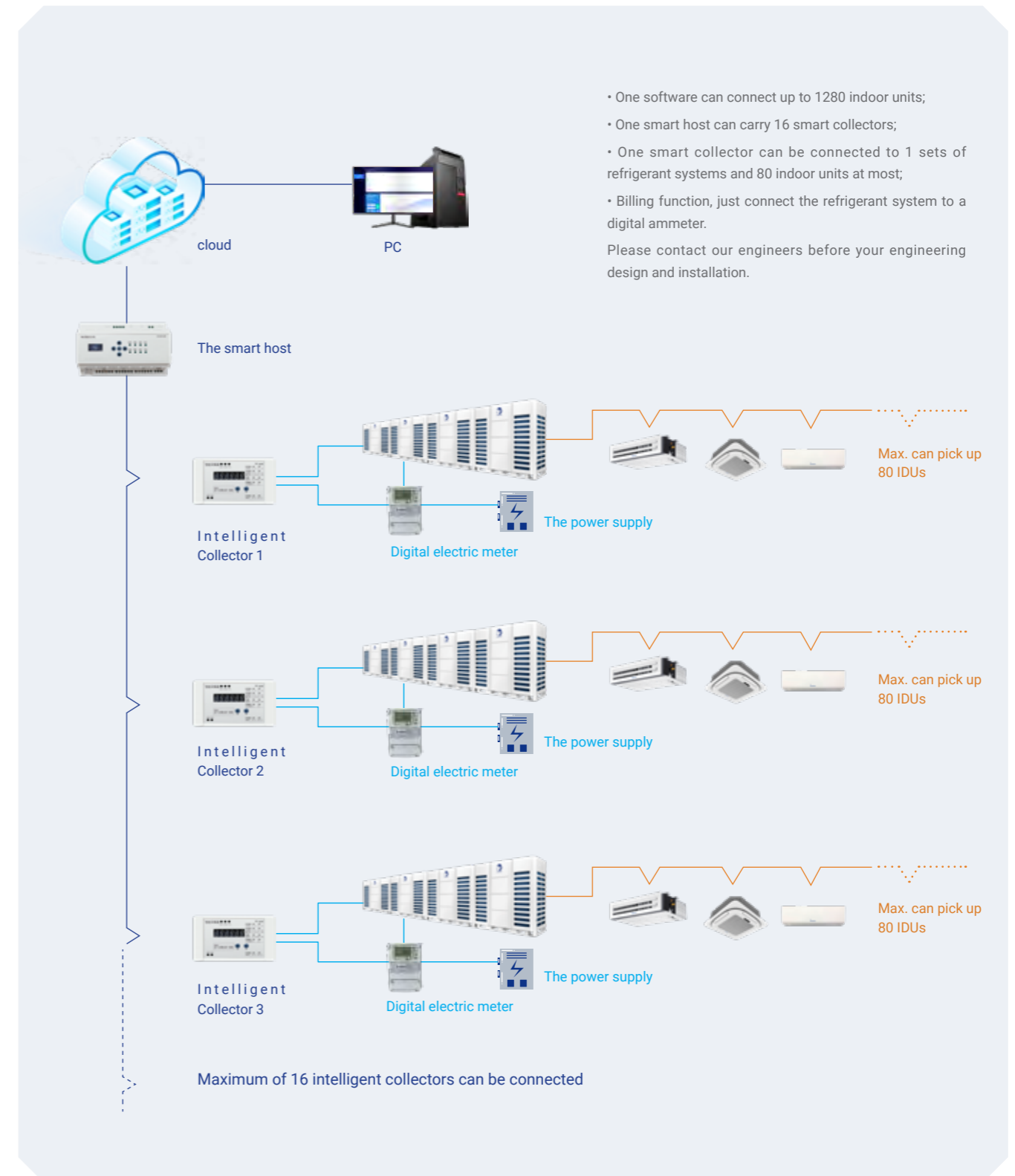

- One software can connect up to 1280 indoor units;
 - One smart host can carry 16 smart collectors;
 - One smart collector can be connected to 1 sets of refrigerant systems and 80 indoor units at most;
 - Billing function, just connect the refrigerant system to a digital ammeter.
- Please contact our engineers before your engineering design and installation.



4.5 AHU Connection KIT

- Solution to extend NØRDIS VRF technology to third party Air Handling Units.

- ✓Easy for connecting to third party AHU
- ✓Setting capacity by DIP
- ✓Remoter or wire controller can be chosen
- ✓3 steps fan motor speed, Low/Mid/High
- ✓Error status: No error or error occurred

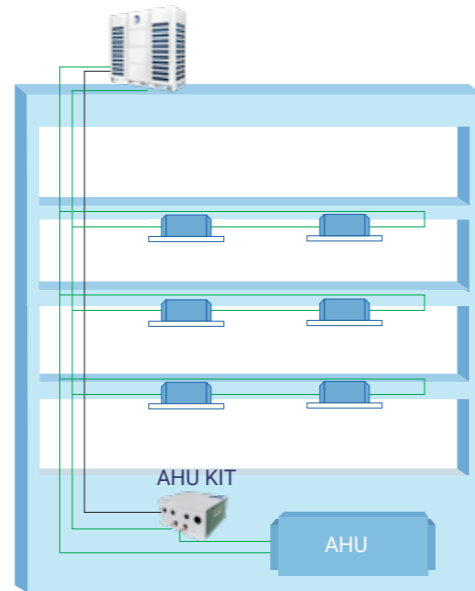

Communication wire

Refrigerant pipe

Type	Model Name	Capacity	Combination				Description
			ODU	Motor	Pump	Warning signal	
Communication Kit	NV6-BK3	16-40 Kw	NV6	✓	✓	✓	Room air supply by remote controller or wiring controller
	NV6-BK4	40-65 Kw		✓	✓	✓	
	NV6-BK5	65-80 Kw		✓	✓	✓	

4.6 BMS Gateways

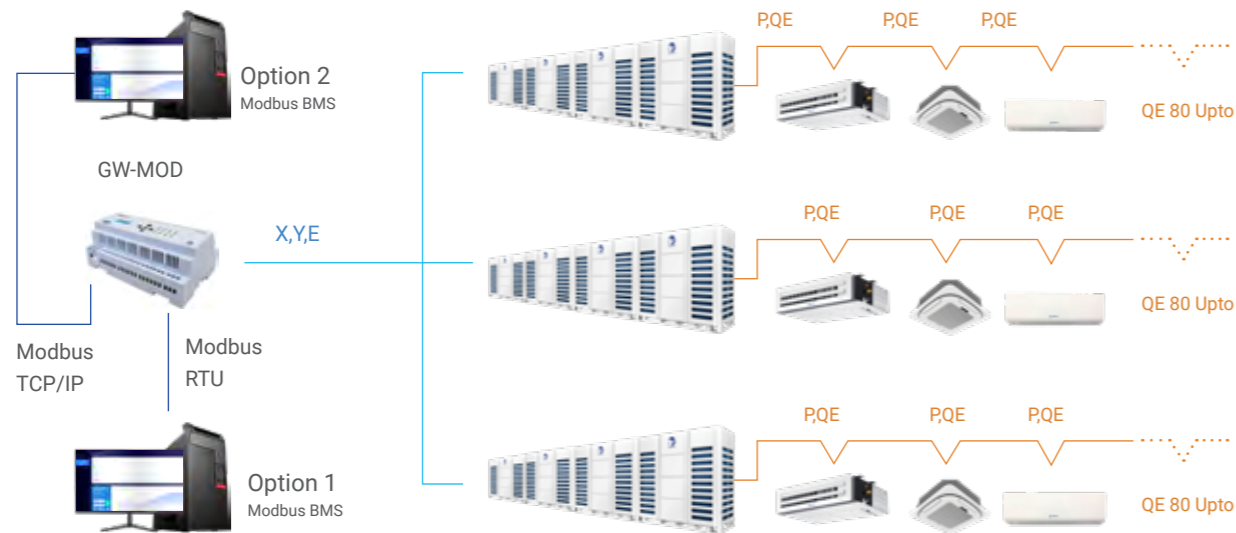

Separate billing and Arrear lock function

- It can store six-month household billing datas, electricity bill query and other functions, users can check and print the bills of each indoor unit.
- Maximum 16 refrigerant systems, 32 ammeters, 1280 indoor units can be connected.
- Auto searching indoor and outdoor units in the system.
- Users can set billing parameters for different time periods according to the peaks and valleys.
- The air-conditioning system of the arrear user can be locked.



Remote and centralized control function

- Real-time monitor the operating conditions of indoor and outdoor units.
- It can monitor and control up to 1280 indoor units, with single, group, and central control.
- The indoor and outdoor units can be configured according to the actual requirement.



Powerful schedule management function

- With monthly/weekly/daily timer and exception date (specified by the user) , the user can control the indoor unit according to personal plans.
- Single or group IDUs can be controlled according to the final user requirement.



Data analysis function

- System operation data and system failure can be recorded and analyzed;
- Operation log will record the user operations.



Key card function

Connected and controlled with hotel key card, the air conditioner can be automatically powered on/off when guests inserts or pulls out the key card.

When insert the key card, air conditioner will start automatically.

When power off, the air conditioners in other rooms can continue to work, even under same system.

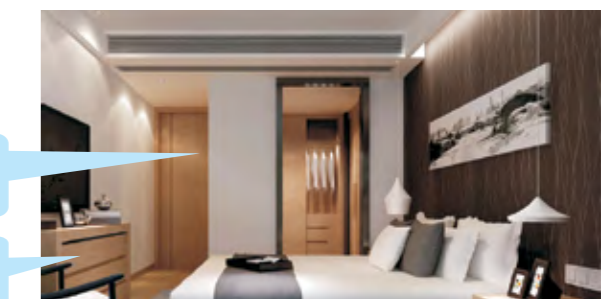



STABLE AND RELIABLE PERFORMANCE

NØRDIS has always insisted on making high-quality products relying on advanced manufacturing equipments and deep technical accumulation. Excellent performance guarantees the stability operation.

NØRDIS VRF can make sure stable and high-efficient operation facing the complex and changeable working conditions.



Inverter module cooling protection technology



Six levels oil return technology



High precision refrigerant control technology



-25 ° C ~ 56 ° C
Ultra wide operating temperature range



Pressure self-regulating technology



Triple backup function



Rotation function



Multiple protections



5.1 6- Stage oil return technology

- NV6 is at the leading position on the oil separate, oil return, oil balance and storage technology. The oil system equipped with precise 6 grade management to make sure compressor safety, stability and reliability.

Multistage Oil Control Technology

- The VRF system have sufficient and balanced oil in working condition to ensure safety and avoid potential oil shortages.

- Level 1: Compressor internal oil separate
- Level 2: Compressor external oil separate
- Level 3: High-efficiency centrifugal oil separator
- Level 4: Oil balance pipes between compressors to ensure compressors running normally
- Level 5: Automatic oil balance system improves the compressor reliability
- Level 6: Smart oil return program to ensure the oil return completely

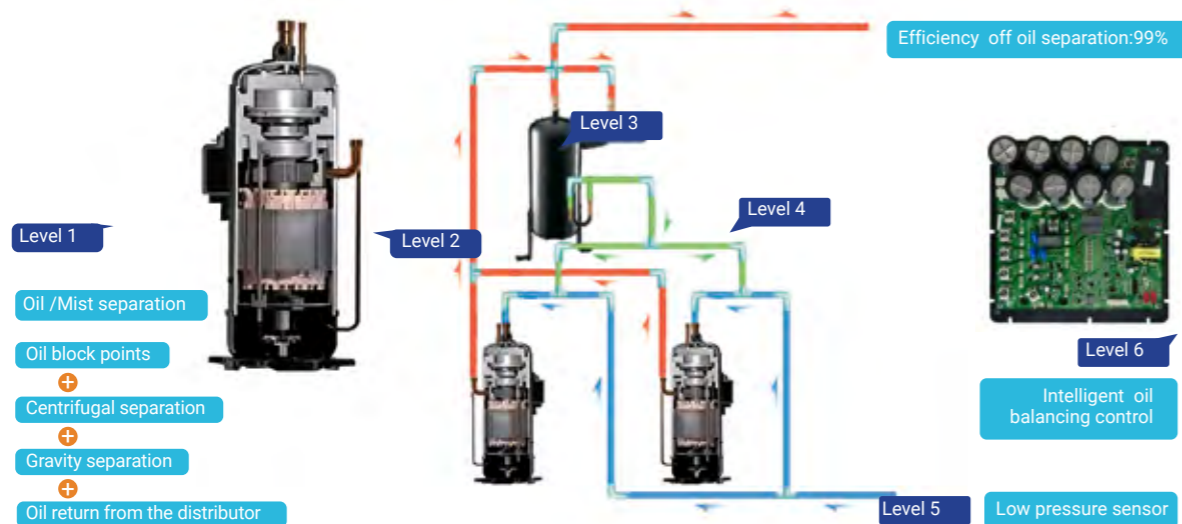

Automatic oil balancing

- Oil balancing system improves compressor oil storage and reliability, which also ensures the unit in good performance in cooling / heating mode.

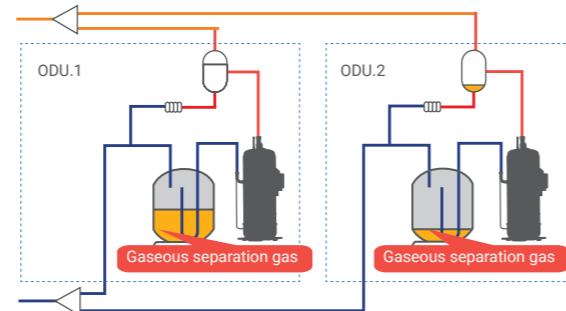

5.2 Inverter module cooling protection

- When the outdoor units are running, high temperature will decrease the compressor frequency, reduce the cooling capacity, and shorten the life time. Traditional air-cooled method can make high thermal conductivity and worse heat dissipation performance, but NØRDIS module cooling technology can eliminate the heat of PCB, reduce the working temperature of inverter module and improve the PCB system reliability.

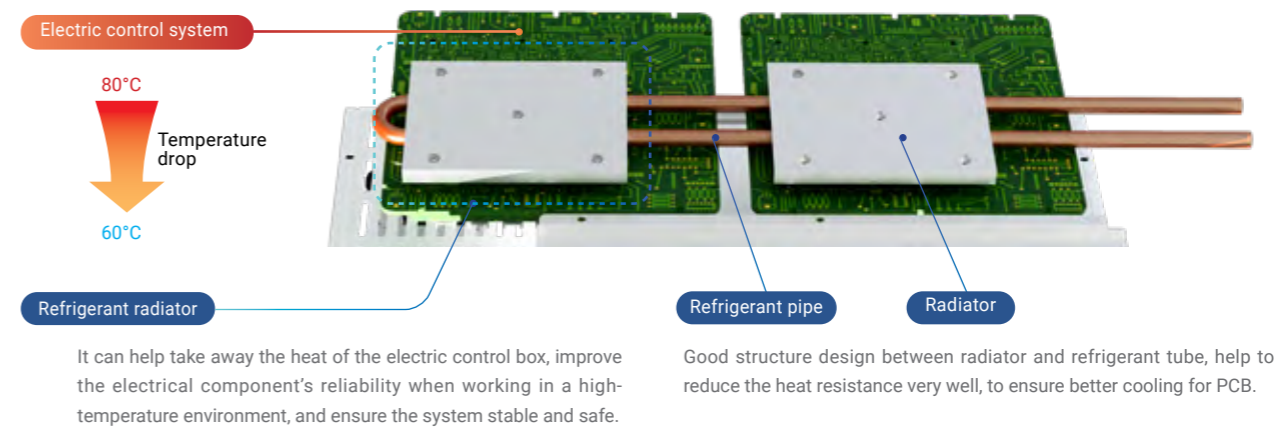

5.3 High precision refrigerant control function

- The upgraded technology allows the system to manage the volume of refrigerant, and also reduce the refrigerant in entire system and increase efficiency.
- Liquid bypass control technology use multi-electronic expansion valve, it can adjust the refrigerant flow and control the overheating degree of the compressor, ensure the compressor to be highly efficient, safety and reliable.

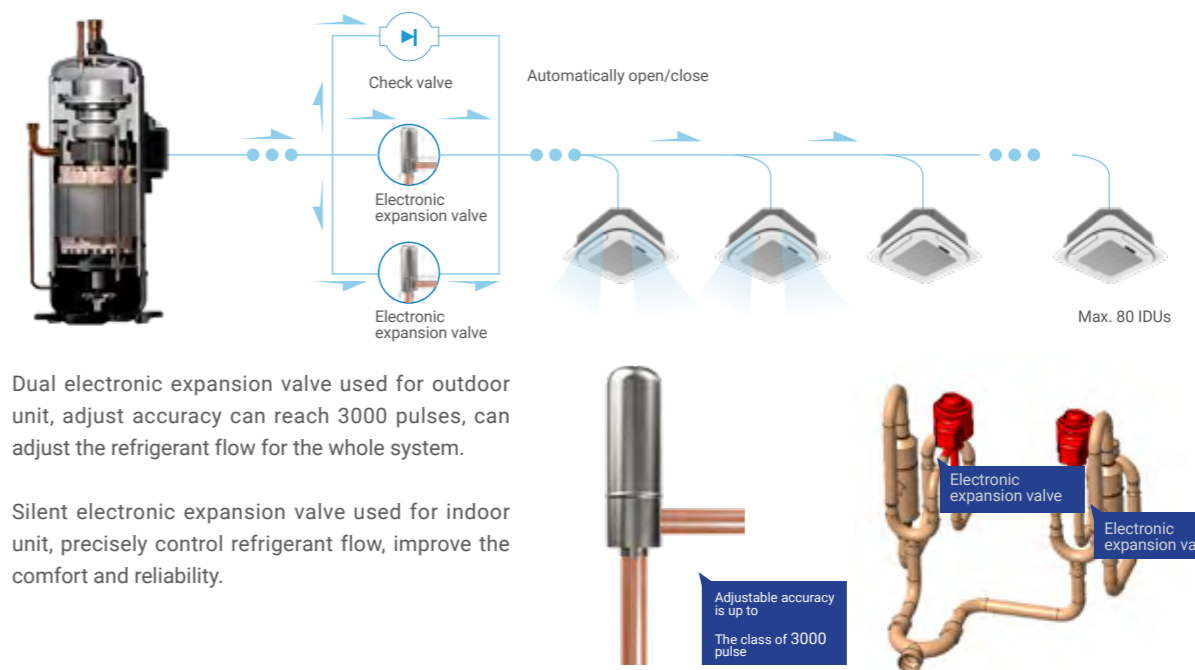

* Note: General adjustment is 480 level, can be customized to 3000 level adjustment



5.4 Wide voltage range

- The unit can operate in the range of voltage 290V~460V (International standard voltage 380V±10%), satisfy all kinds of voltage conditions.

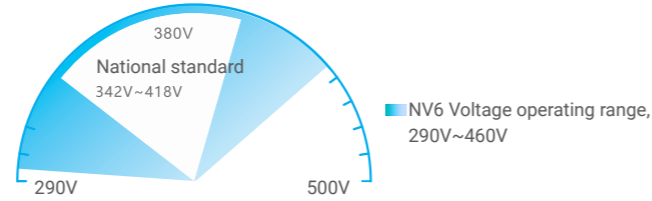

5.5 Wide operation temperature range -25°C ~56°C

- Wide operation range, cooling: -5°C~56°C heating: -25°C~28°C.

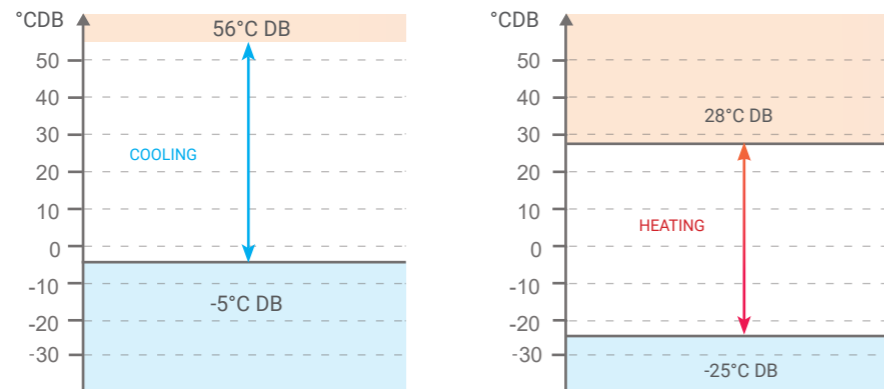

5.6 Pressure self-adjustment technology

- Pressure sensor is used to check system pressure, and adjust compressor operation frequency, fan speed, electronic expansion valve, to ensure the system with the best performance

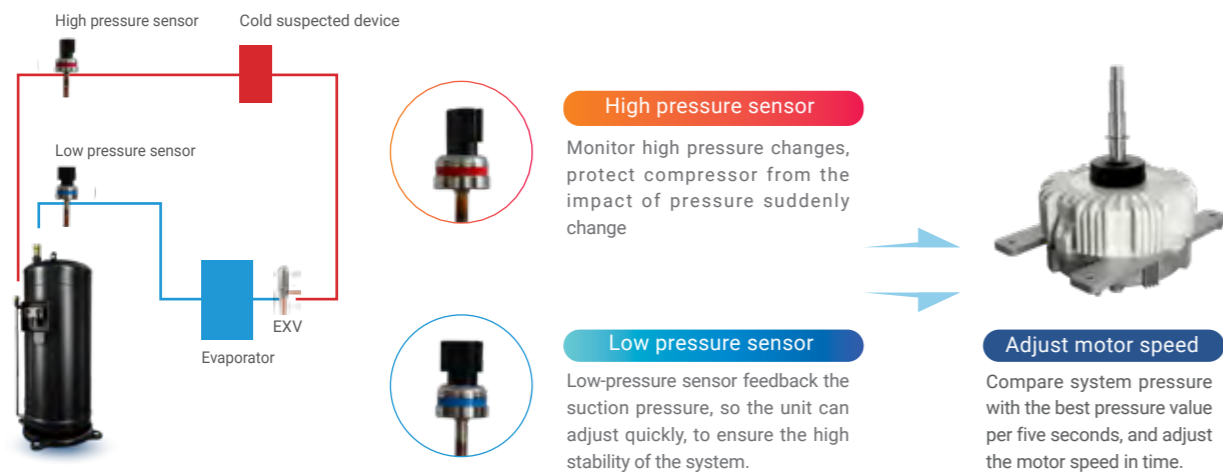

5.7 Triple back-up operation technology

Compressor backup operation

- In units with two compressors, if one compressor fails, the other compressor can run on its own, to ensure the air conditioning system can work stably.

Running state
Standby
Failure or shutdown status



Running state



Emergency operation

Emergency operation of fan motor

- Some outdoor units are designed with dual fan, if the one fan motor fails, the other motor also can work normally, to avoid impact consumer's work and life.

The normal operation
The fault



The normal operation



Emergency

ODU backup operation

- In a multi-unit system, if one outdoor unit fails, the other modules provide backup so that the system can continue operating.

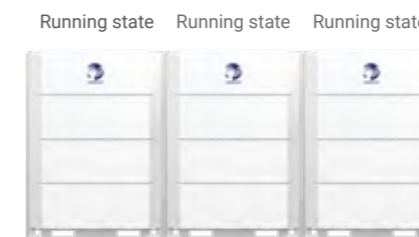

Running state

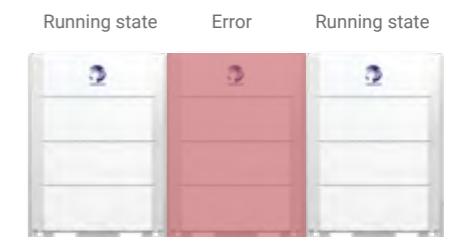

Emergency operation

5.8 Rotation operation technology

- If the system is connected to multiple modules, in order to ensure the balance of compressor operation, the automatic control of the microprocessor on the host can realize the automatic rotation operation function between the modules, effectively extend the service life of the unit.



5.9 Multiple protection functions

- Multiple protection functions to ensure the safe operation of the system.



Anti-adversity function

- The external force blows the outdoor unit fan to rotate in reverse. At this time, start and stop the rotation of the fan, and then restart the fan motor in a forward rotation according to the normal procedure, so as not to damage the fan blades due to excessive starting current.

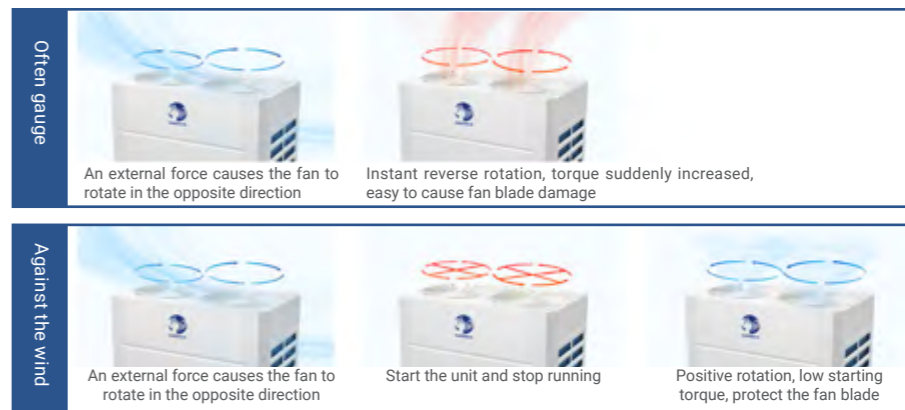

Phase sequence protection

- When the power cord of the outdoor unit is connected incorrectly, the circuit will start self-protection to avoid impact and damage to the main control board, inverter module and compressor. Ensure the normal operation of the air conditioner, without accidental electrical damage, fire, etc.

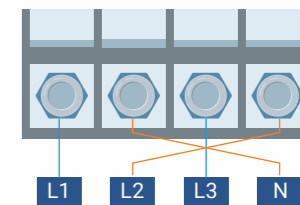

Low voltage recognition function

- Automatically recognize the working voltage, when the voltage is too low, give an early warning in time, and control the power consumption and capacity output of the multi-line system through the corresponding limit frequency.

Lightning protection

- The outdoor unit has a built-in anti-seismic module, which has anti-seismic and anti-interference functions to ensure the safe and stable operation of the system in bad weather.



Compressor overload protection

- When the compressor casing or motor temperature is too high, the circuit will automatically cut off to prevent the compressor from overloading and cause electrical damage, fire, etc.



Motor overheating protection

- When the current exceeds the set value, the temperature will rise, and the motor will be cut off in time during overcurrent operation to protect the motor from burning due to overload.

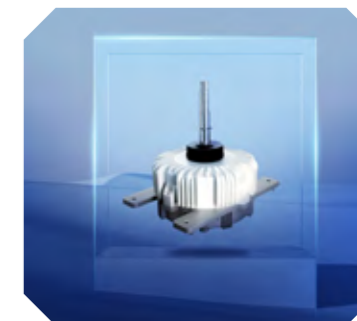



5.10 Anticorrosion design

Hydrophilic aluminum fin

- It adopts anti-corrosion and anti-oxidation hydrophilic aluminum foil heat exchange fins, which have multiple protections of lubricating coating, hydrophilic coating and corrosion-resistant coating.



■ Lubrication layer ■ Hydrophilic coating ■ Corrosion resistant coating

Thick sheet metal design

- The surface of the sheet metal parts is phosphated and coated with special anti-corrosion materials. It improves the salt spray resistance and heat and humidity resistance, and greatly improves the anti-corrosion ability of the sheet metal.



Special corrosion-resistant coil

- Use special anti-corrosion coils. The base layer of ordinary galvanized sheet is increased with electrophoretic layer to achieve anti-corrosion effect. The coil fixing screws are stainless steel screws.



Motor protection upgrade

- Improve the protection level of the motor. The motor shaft is made of stainless steel. During the installation process, the motor shaft, nuts, gaskets and exposed motor shaft are coated with anti-rust grease, and the motor body screws and top cover screws are coated with silicone grease.

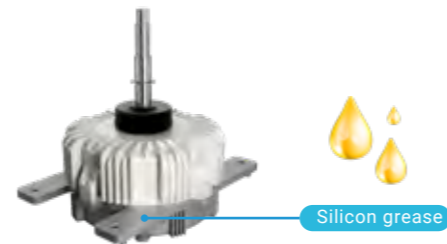

Electric control anti-corrosion

- The main board is equipped with moisture-proof glue, the sheet metal surface of the electric control box is treated with anti-corrosion spray, and the top of the metal casing fan capacitor is sprayed with anti-corrosion paint separately.

Pressure vessel

- It adopts surface phosphating treatment with good anti-corrosion performance.

Fastener

- The nails, nuts and washers are made of stainless steel or high anti-corrosion materials, and the screw heads inside the machine and outside the electric control box are coated with silicone grease for anti-corrosion.

Copper pipe weld

- Anticorrosive paint is sprayed on the welded joints of copper pipes.

5.11 Electronic control board SMT placement technology

- The electronic control main board adopts SMT patch sealing technology to improve the anti-clutter interference, to ensure that the main board is not affected by wind, sand, high temperature and high humidity, and to make the main control board longer.



5.12 Automatic anti-snow function *

- In the snowy weather conditions in winter, in order to prevent the snow from adversely affecting the top of the outdoor unit fan, the unit will automatically turn on the fan to clear the snow to ensure the normal operation of the unit.



5.13 Fan reverse dust removal function

- The DC fan reverse operation technology can effectively automatically remove dust and clean the inside of the heat exchanger, improve the cleanliness of the heat exchanger, increase the heat exchange efficiency, and prolong the service life of the product.



5.14 High-altitude adaptive technology

- In high-altitude areas where the air is thin, the unit is prone to insufficient capacity. The NV6 outdoor unit can automatically recognize the altitude position. When the altitude is too high and the capacity is insufficient, the high altitude adaptive mode will be activated for automatic compensation, which will greatly increase the fan speed and increase the air volume.

5.15 Circuit auto-repair function

- The NV6 has the automatic repair function of the electronic control circuit, which can promptly alarm and realize the automatic repair of the circuit in the event of an accident, improve system reliability, and ensure stable system operation.



5.16 Black box function

- The unit is equipped with a "black box" data storage device, which records operating parameters before failure, quickly finds failure information, provides effective information for maintenance, and improves maintenance efficiency.

* Note: This function needs to be customized



CONVENIENT INSTALLATION AND MAINTENANCE

For different application scenarios, different installation environments should be taken into consideration. The NV6 takes every detail into consideration, in the product appearance design and function, which greatly improves the convenience of installation, speeds up the installation speed, and also improves the convenience of maintenance.



15 basic modules, satisfy all kind of requirement



Big-capacity module design, easy installation and space saving



Super long refrigerant pipeline design, flexible structure



Auto-refrigerant detecting and autocharging function



130Pa The highest static pressure for outdoor unit



Convenient for the transportation, installation and commissioning



Auto-addressing function



ODU without oil balance pipe, compact design



Emergency power-off function for indoor unit maintenance



Commissioning software





6.1 Intelligent multi-connection, easy to cope with the spatial layout

- In order to meet the needs of different building types for air conditioning equipment, 15 basic outdoor unit modules are provided. The modules of 8-36HP can be combined freely, and the maximum combination can reach 144HP. There are 9 categories of indoor units, with more than 100 models to choose. The maximum internal unit capacity is 56kW. Outdoor units and indoor units can be freely matched and multi-connected. A system can connect up to 80 indoor units to meet the needs of different buildings.

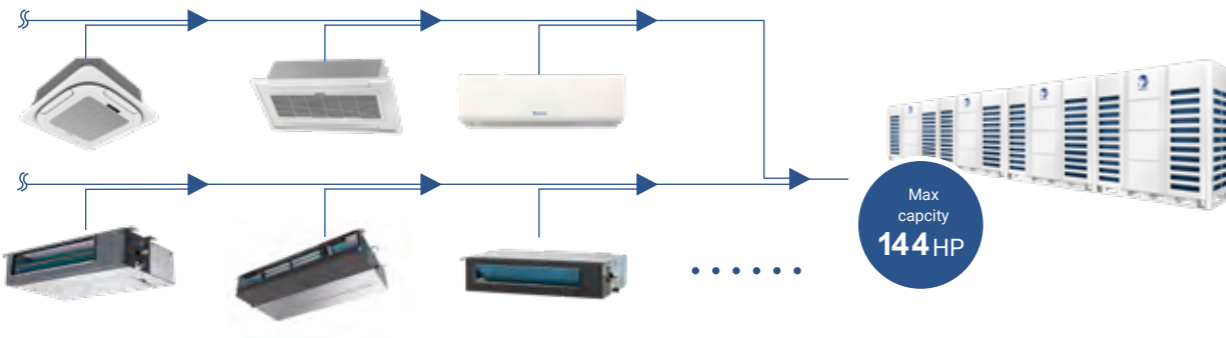

6.2 Large-capacity module design, convenient installation and space saving

- The maximum capacity of a single machine is 36HP.
- Smaller body size saves installation space.
- Reduce the workload of wiring, save labor cost and construction period.
- Less installation materials, saving purchase costs.

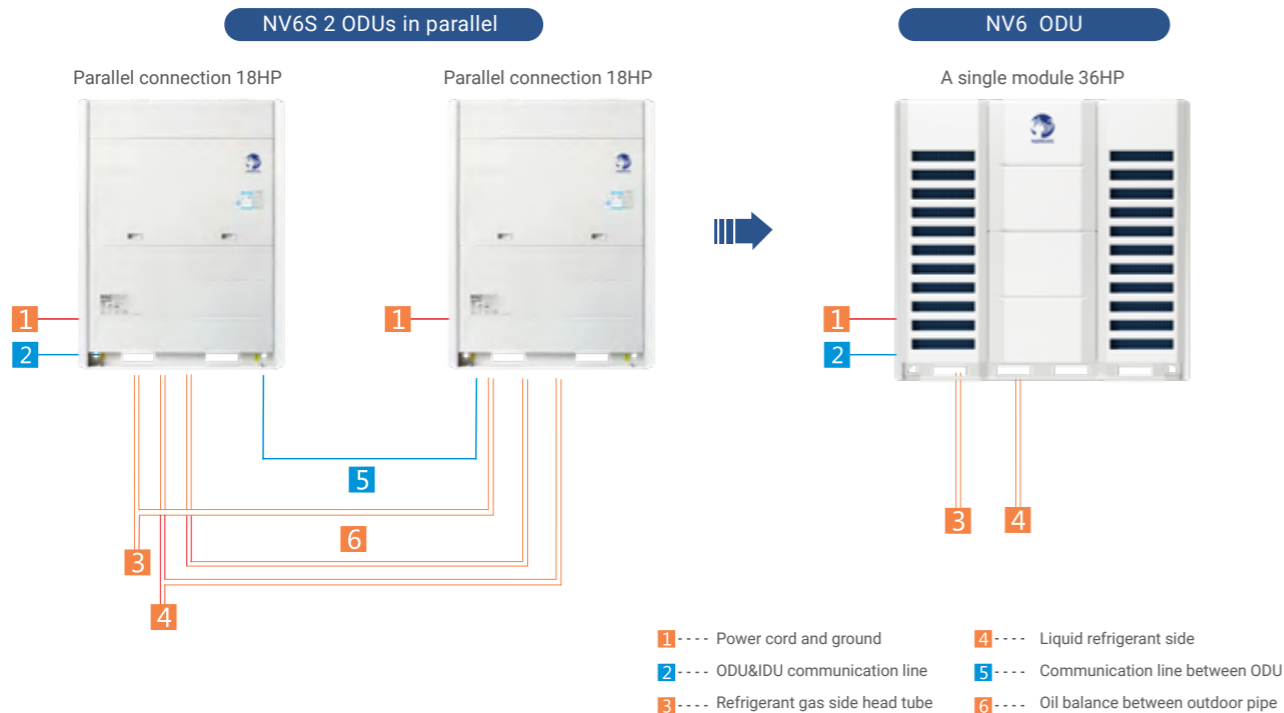

6.3 1100 m Super long piping design

- The industry-leading piping length, with a total length of 1100m, makes floor design more flexible.
- The max distance between the IDU and the ODU (the higher ODU) is 100m. The max distance between the IDU and the ODU (the lower ODU) is 110m.
- The maximum distance between indoor units is 40m.
- The maximum actual single pipe length is 220m. The maximum equivalent single tube length is 240m.
- The equivalent length from first indoor distributor to last indoor unit is 120m.

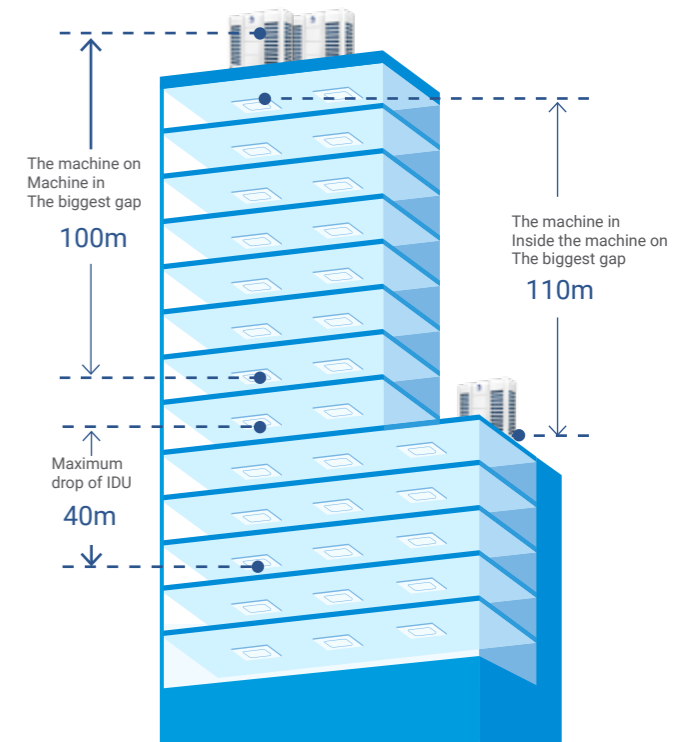
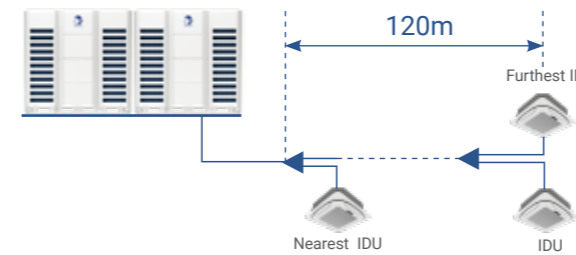

6.4 Single system can connect 80 IDUs

- NV6 adopts the international advanced CAN bus communication technology, and one system can connect up to 80 indoor units, ensure stable and reliable in operation, realizes a large-capacity configuration of a single system, and is more flexible in engineering applications.

6.5 130 Pa external static pressure

- The system achieves a higher external static pressure, up to 130Pa* (factory default external static pressure) blades through the joint action of new fan blades and fans with larger air volume. Inverter fan motor. 85Pa) to ensure the layered or concentrated heat dissipation effect of the outdoor unit.

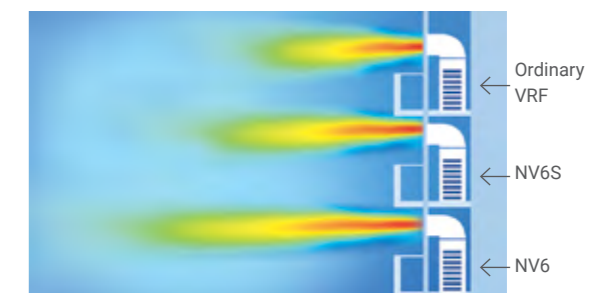
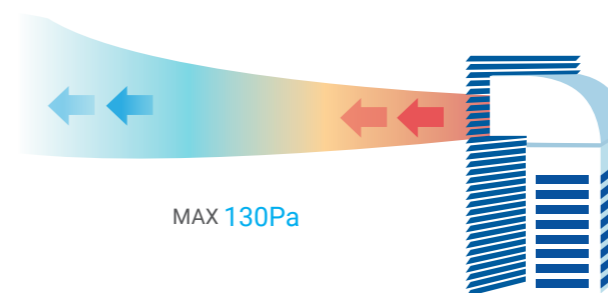

Better heat dissipation, better refrigeration effect

VRF static pressure contrast diagram

* Note: 130Pa static pressure needs to be customized



6.6 Automatic refrigerant judgment and charging

Automatic refrigerant judgment

- According to the operating status of the system, it will ensure real-time monitor of the amount of refrigerant, intelligent judgment, stable operation of the system.

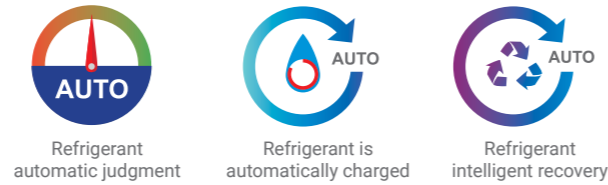

Automatic refrigerant charging

- During the installation and maintenance process, the refrigerant can be charged automatically according to the system status.

Smart refrigerant recovery function*

- When the system is maintained, the refrigerant is recovered intelligently, which is convenient and quick.



6.7 Compact design and convenient transport

- The outdoor unit module has only 4 basic structures with the same height, which simplifies the design process and improves the flexibility of the system.

- Elevator transportation is convenient, no need large equipment such as hoisting, which effectively simplifies the transportation work and saves construction time and manpower.

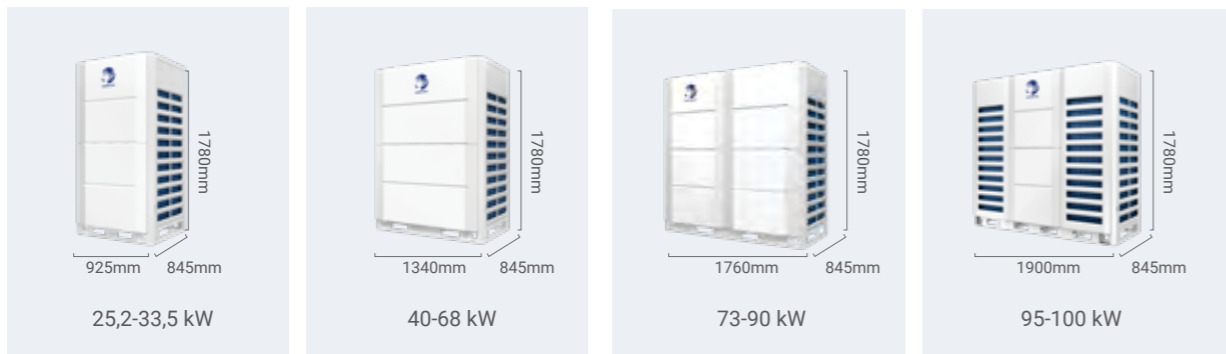

6.8 One-button commissioning function

- You can choose to perform a one-button trial running on the outdoor unit side, or perform a one-button trial running on any indoor unit side to achieve cooling and heating trial operation, no need turning on the indoor units one by one, facilitating on-site commissioning and improving the quality of project site construction.

6.9 Non-polarity communication connection

- CAN bus communication mode is applied between indoor and outdoor unit, no need to distinguish between positive and negative poles, and the installation is simpler and more efficient.

6.10 No oil balance pipe for ODU

- The outdoor units without oil equalizing pipe, which are more convenient for installation and also reduces the error of pipeline leakage.

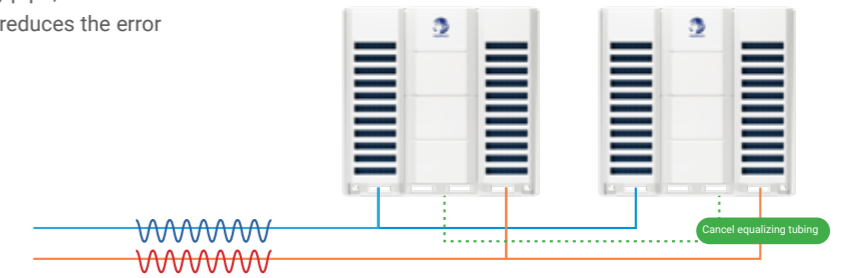
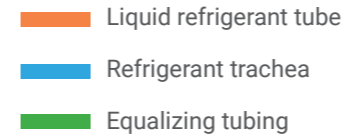

6.11 360° pipe connection design

- The units can connect the pipes in multiple directions freely, such as the front side, the left side, and the right side, to make the installation more convenient.



6.12 Emergency power-off function for IDU maintenance

- If an indoor unit needs to be powered off for maintenance due to failure, in order not to affect the operation of the entire system, the indoor unit can be powered off separately for maintenance, and other indoor units in the system can operate normally.



6.13 Commissioning software

- The commissioning software is specially developed for NØRDIS air-conditioning system, which can carry out real-time status monitoring and loading control of the air-conditioning system.
- It can monitor the real-time operation parameters of 4 outdoor units and 80 indoor units in parallel system; And the operating parameters can be showed in Curve; It contains the function of saving the original data of operation, which is convenient for the R & D Engineers to remotely analyze the cause of failure; It also contains the forced load control function of the equipment, which is convenient for loading maintenance verification on the project site.

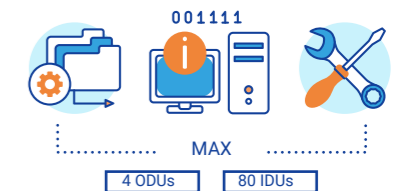

6.14 Auto-addressing function

- The system can realize the automatic allocation of indoor unit address. There is no need to dial code during commissioning, which avoids the trouble of manual setting one by one. It is more intelligent and convenient.





ODU lineup



25,2-33,5 kW



40-68 kW



73-90 kW



95-100 kW

Note: 34HP/36HP are the models of enhanced vapor injection, which can enhance the heating performance under low ambient condition, others are regular models.

ODU parameters (8-36 HP)

Loading Capacity		25200	280000	33500	40000	45000	50400	56000	61500	68000	73000	78500	85000	90000	
Model		NV6-252-T3/R1-ODU	NV6-280-T3/R1-ODU	NV6-335-T3/R1-ODU	NV6-400-T3/R1-ODU	NV6-450-T3/R1-ODU	NV6-504-T3/R1-ODU	NV6-560-T3/R1-ODU	NV6-615-T3/R1-ODU	NV6-680-T3/R1-ODU	NV6-730-T3/R1-ODU	NV6-785-T3/R1-ODU	NV6-850-T3/R1-ODU	NV6-900-T3/R1-ODU	
Cooling capacity	Capacity	W	25200	28000	33500	40000	45000	50400	56000	61500	68000	73000	78500	85000	90000
	Input	W	7850	8890	12500	14550	18000	19530	24240	30000	31480	39460	34450	39950	45000
	Current	A	12.52	14.18	19.94	23.21	28.71	31.15	38.66	47.85	50.21	61.00	54.95	63.72	71.77
Heating capacity	Capacity	W	25200	28000	33500	40000	45000	50400	56000	61500	68000	73000	78500	85000	90000
	Capacity Max	kW	27	31.5	37.5	45	50	56	63	69	75	81.5	87.5	95	100
	Input	W	6000	7180	9100	11430	15000	13810	16100	18700	18630	24750	23760	26130	28125
	Current	A	9.57	11.45	14.51	18.23	23.92	22.03	25.68	29.82	29.71	39.47	37.91	41.67	44.86
SEER	Duct		7.31	7.22	7.05	6.75	6.2	6.5	6.3	6.2	6.5	5.5	6.3	6.2	6.0
	Cassette		7.35	7.26	7.04	6.75	6.25	6.61	6.41	6.18	6.2	5.38	6.0	5.9	5.8
SCOP	Duct		4.5	4.45	4.4	4.42	4.39	4.4	4.35	4.3	4.5	4.1	4.15	4.13	4.13
	Cassette		4.4	4.38	4.32	4.4	4.35	4.22	4.15	4.25	4.38	4.16	4.3	4.2	4.2
Power supply			380-415V 3N ~ 50Hz												
Outdoor noise level (sound power level)	dB(A)		83	84	86	90	93	93	93	93	93	93	93	93	93
Max. Power	kW		11300	12430	13730	18400	21390	23700	26070	31490	33270	41250	39440	41250	48700
Max. Current	A		20.03	22.03	24.33	32.6	37.9	42	46.2	55.8	58.95	66.9	69.9	73.1	79.06
Compressor	Freq. Range	Hz	20-120												
	Crankshaft heating belt	W	70												
Outdoor fan motor	Model		ZKSN-560-8-48L			ZKSN-920-8-40L		ZKSN-560-8-48L		ZKSN-920-8-40L					
	Type		Plastic brushless DC motor												
	Qty		1	1	1	1	1	2	2	2	2	2			
	Output	W	560	560	560	920	920	560	560	560	920	920			
Air volume	m ³ /h		11000	11000	11500	13500	14000	19000	19000	20000	26000	26000	29000	29000	29000
Connecting Pipe	Liquid	Inches	3/8"	3/8"	1/2"	1/2"	1/2"	5/8"	5/8"	5/8"	3/4"	3/4"	3/4"	3/4"	3/4"
	Gas	Inches	3/4"	7/8"	1"	1"	9/8"	9/8"	9/8"	9/8"	5/4"	5/4"	5/4"	3/2"	3/2"
	connection method		Welding												
Net dimensions (L x W x H)	mm		925*845*1780			1340*845*1780			1900*845*1780						
Packing dimensions (L x W x H)	mm		1000*925*1940			1415*925*1940			1975*925*1940						
Weight	Net weight	kg	215	215	215	270	270	315	315	320	380	380	380	380	455
	Gross weight	kg	225	225	225	290	290	335	335	340	405	405	405	405	480
Refrigerant	Type		R410A												
	Charged volume	kg	9	9	9	11	11	14	14	16	18	18			
CO2 equivalent	tonnes		18 792	18 792	18 792	22 968	22 968	29 232	29 232	33 408	37 584	37 584	37 584	37 584	58 464
Design pressure	MPa		4.3												
Cooling operating range	Outdoor side	°C	-5~55												
	Indoor side	°C	16~32												
Heating operating range	Outdoor side	°C	-30~28												
	Indoor side	°C	15~31												

Note:

- Specifications are based on the following conditions:
- Cooling: Indoor temperature 27°C DB/19°C WB, and outdoor temperature 35°C DB/24°C WB.
- Heating: Indoor temperature 20°C DB/15°C WB, and outdoor temperature 7°C DB/6°C WB.
- Equivalent piping length: 5m; Level difference: 0m; Voltage: 230V.
- Sound Level: Indoor unit sound pressure level, measured at a point 1.5m downward from the unit center.

6. Outdoor unit sound pressure level, measured at a point 1.0m in front of the unit.

7. Optional simple wired controller; Universal remote controller; auto-restart (optional); Timer: only one circle.

8. Due to ongoing product development, specifications are subject to change without notice.



VRF systems, Various combinations

- In response to the different needs of building types for air-conditioning equipment, NØRDIS provides four basic outdoor unit modules, which can be freely combined in 2HP increments, and the maximum combination can reach 144HP, which can meet the high level design capacity differentiation, installation and transportation requirements of large and medium-sized air-conditioning projects .



Recommended combination table

HP	Combination	Connected indoor unit qty	HP	Combination1 (Space saving)	Connected indoor unit qty.
8	8	13	66	22+22+22	80
10	10	16	68	22+22+24	80
12	12	19	70	22+24+24	80
14	14	23	72	24+24+24	80
16	16	26	74	22+24+28	80
18	18	29	76	24+24+28	80
20	20	33	78	22+28+28	80
22	22	36	80	24+28+28	80
24	24	39	82	26+28+28	80
26	26	43	84	28+28+28	80
28	28	46	86	26+28+32	80
30	30	50	88	28+28+32	80
32	32	53	90	26+32+32	80
34	16+18	56	92	28+32+32	80
36	18+18	59	94	30+32+32	80
38	16+22	63	96	32+32+32	80
40	18+22	66	98	24+24+24+26	80
42	20+22	69	100	24+24+26+26	80
44	22+22	72	102	24+26+26+26	80
46	22+24	75	104	24+26+26+28	80
48	24+24	78	106	26+26+26+28	80
50	22+28	80	108	26+26+28+28	80
52	24+28	80	110	26+28+28+28	80
54	26+28	80	112	28+28+28+28	80
56	28+28	80	114	26+28+28+32	80
58	26+32	80	116	28+28+28+32	80
60	28+32	80	118	26+28+32+32	80
62	30+32	80	120	28+28+32+32	80
64	32+32	80	122	26+32+32+32	80
			124	28+32+32+32	80
			126	30+32+32+32	80
			128	32+32+32+32	80

Mini VRF

Full DC Inverter MINI VRF Unit



Powerful



High Efficiency



Comfortable



Stable





7.1 Strong power, stable operation

High efficiency full DC inverter and twin rotary compressor

- NØRDIS Mini VRF use full DC inverter twin rotary compressor, which has high- efficiency both for full load condition and partial load condition, also leads to low noise, stable and reliable operation.



High efficiency DC fan motor

- The stepless regulation of the fan motor can meet the actual requirement of the capacity output, efficiency of motor is increased up to be 45%, higher efficiency in low speed operation.



Electrical control box refrigerant cooling technology

- The refrigerant cooling technology can cool the PCBs in high ambient temperature condition, which improves the reliability, efficiency and lifespan of the MINI VRF units.

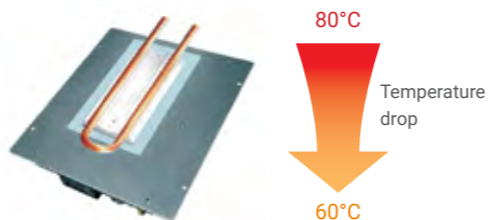

Wide operation temperature range

- The Mini VRF can operate under -20°C to ensure the heating demand, operate up to 54°C to make sure the cooling capacity output with high efficiency and stability.

7.2 Energy saving and environmental friendly

IPLV(C) up to 6.7, high energy efficiency

- The NØRDIS mini VRF adopts full DC inverter compressor, DC fan motor, high-precision electronic expansion valve to create a durable system and make the system energy efficiency up to 6.7.

IPLV(C) ● NØRDIS Mini VRF ● National level 1 energy efficiency standard

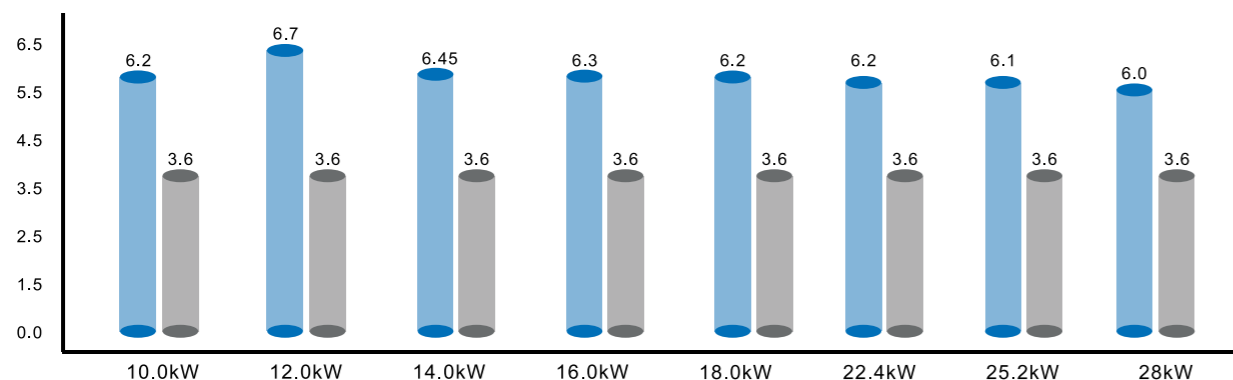

R410A High-efficiency and environmentally friendly refrigerant

- R410A is an HFC refrigerant which does not damage the ozone layer. It is an energy efficient and environmentally friendly refrigerant.
- R410A is non-toxic and is a "non-flammable refrigerant". The composition structure of R410A is not easy to change and very stable.



RoHS Certification

- The NØRDIS mini VRF unit meets the RoHS environmental certification, which is environmental friendly.



7.4 Beautiful appearance, upgraded structure design

Simple and elegant appearance

The top panel
No screw design to get high-quality structure and improve the strength, more beautiful

The front panel
Double 528mm wind wheel, larger air volume and lower noise.

Grille
Grille adopts DOE simulation design, air volume increased more than 7%

Footing
High strength foundation with rust - proof, corrosion - proof, more stable and reliable.

Right front side plate
Mold forming and integrated design to make sure the strength of the panel

Lifting handle
Upgraded handle design, easy to carry

Right back plate
The mold is integrally formed and the new designed diffuser improves the heat exchange efficiency.

Seal plate
Ensure simple pipe connection.

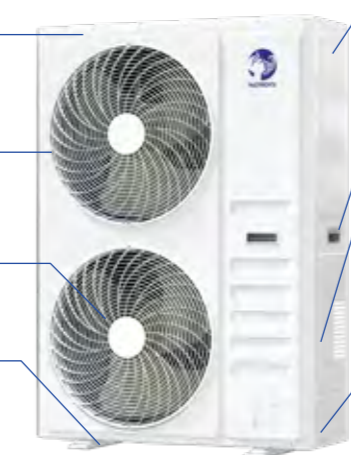

Three side direction pipe connection

- The front, side and back of the unit are designed with knock-out holes, copper pipes can be connected from various directions, which is more convenient to do the installation.



Sealing plate is combined with knock-out plate
Three side pipe connection design
Different installation options



7.5 Mini VRF Parameters



			NV6-80F1/ R1-ODU	NV6-100F1/ R1-ODU	NV6-120F1/ R1-ODU	NV6-140F1/ R1-ODU	NV6-160F1/ R1-ODU	NV6-180F1/ R1-ODU	NV6-224F1/ R1-ODU	NV6-252F1/ R1-ODU	NV6-280F1/ R1-ODU	
Cooling capacity	Capacity	W	8,000	9,000	12,100	14,000	15,500	18,000	22,400	25,200	28,000	
	Input	W	2700	2900	3900	5250	5930	6900	9220	8600	11280	
	Current	A	12.1	13	17.31	23.34	26.06	10.75	14.2	13.23	16.62	
Heating capacity	Capacity	W	8,000	9,000	12,100	14,000	16,000	18,000	22,400	25,200	28,000	
	Capacity Max	kW	8.5	10	14	16	18	20	24.5	27	30.8	
	Input	W	2100	2900	3100	3800	4520	4900	6220	7030	8070	
	Current	A	9.41	13	13.9	16.6	19.86	7.63	9.34	10.9	12.46	
SEER	Duct		5.4	5.4	7	6.9	6.8	7	6.8	6.6	6.4	
	Cassette		5.4	5.4	6.95	6.85	6.75	6.95	6.75	6.55	6.35	
SCOP	Duct		3.8	3.8	4.3	4.2	4.2	4.4	4.2	4.3	4.3	
	Cassette		3.8	3.8	4.25	4.15	4.15	4.35	4.15	4.25	4.25	
Power supply			220-240V~/50Hz					380-415V 3N ~ 50Hz				
Outdoor noise level (sound power level)	dB(A)		69/71	69/72	70/72	70/73	71/74	78/79	78/79	80/82	80/82	
Max. Power	kW		6.2	6.2	7.26	7.26	7.26	11.00	11.0	12.0	12.0	
Max. Current	A		28.2	28.2	33.0	33.0	33.0	17.6	17.6	19.2	19.2	
Air volume	m3/h		4300	4300	5700	5700	5700	10500	10500	10500	10500	
Connecting Pipe	Liquid	Inches	3/8"	3/8"	3/8"	3/8"	3/8"	3/8"	3/8"	3/8"	3/8"	
	Gas	Inches	5/8"	5/8"	5/8"	5/8"	5/8"	7/8"	7/8"	7/8"	7/8"	
Net dimensions (LxWxH)		mm	910x359x803			1010x410x850			1120x400x1560			
Packing dimensions (LxWxH)		mm	1022x480x835			1145x535x970			1250x560x1721			
Weight	Net weight	kg	52	52	75	75	78	130	130	140	140	
	Gross weight	kg	55	55	87	87	90	145	145	163	163	
Refrigerant	Type		R410A	R410A	R410A	R410A	R410A	R410A	R410A	R410A	R410A	
	Charged volume	kg	2.3	2.3	3.7	3.7	4.2	6.5	6.5	8.5	8.5	

Note:
 Specifications are based on the following conditions:
 Cooling: Indoor temperature 27°C DB/19°C WB, and outdoor temperature 35°C DB/24°C WB.
 Heating: Indoor temperature 20°C DB/15°C WB, and outdoor temperature 7°C DB/6°C WB.
 Equivalent piping length: 5 m; Level difference: 0 m; Voltage: 230 V.
 Sound Level: Indoor unit sound pressure level, measured at a point 1.5 m downward from the unit center.
 Outdoor unit sound pressure level, measured at a point 1.0 m in front of the unit.
 Optional simple wired controller; Universal remote controller; auto-restart (optional); Timer: only one circle.
 Due to ongoing product development, specifications are subject to change without notice.

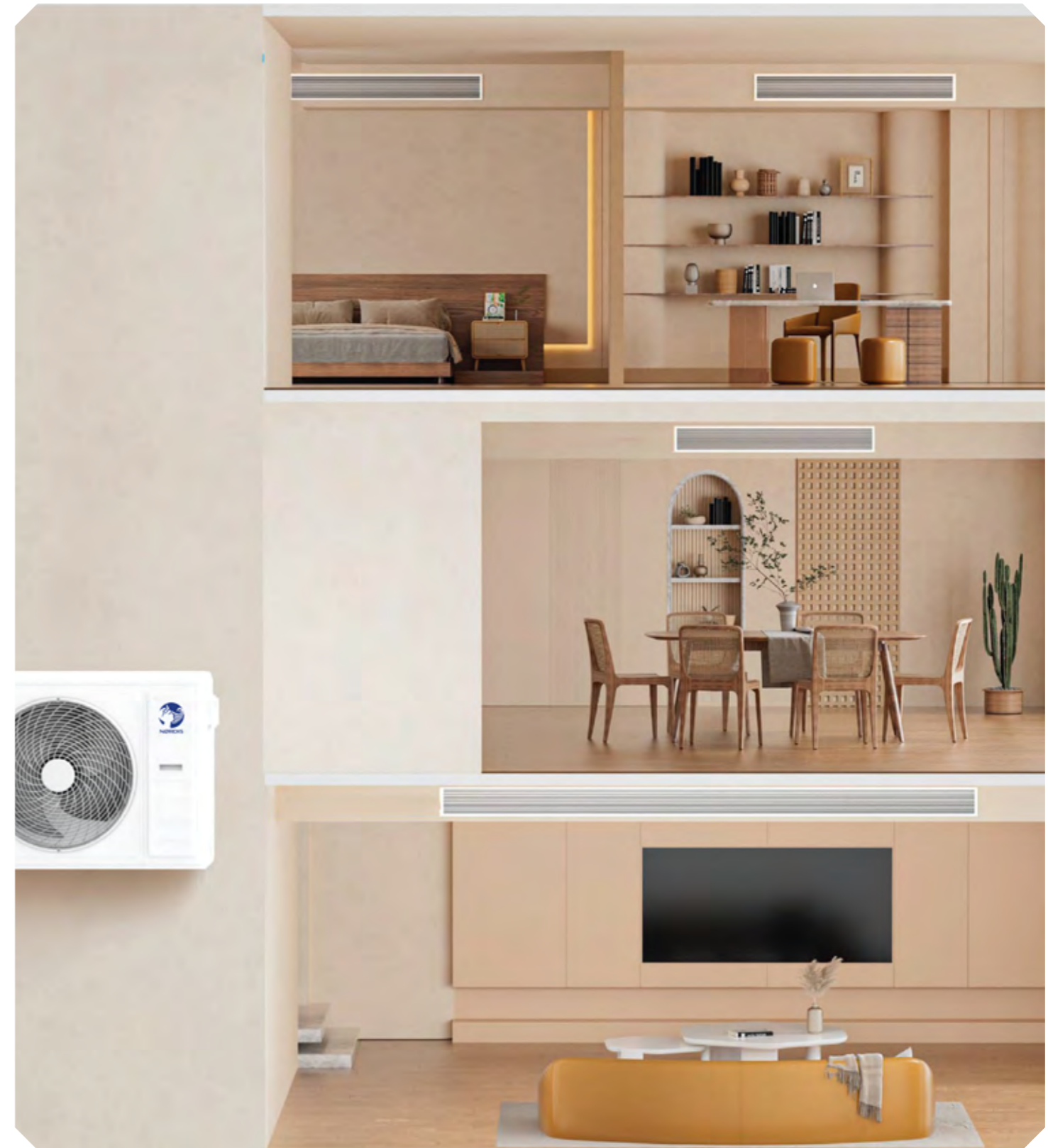



Series	Type	Model	Capacity range(x100w)																										
			18	22	25	28	32	36	40	45	50	56	63	71	80	90	100	112	125	140	160	220	224	280	335	450	560		
One-way cassette	Cooling & Heating	NV6-(**)C1/R1-IDU	●	●		●		●		●	●	●																	
Two-way cassette	Cooling & Heating	NV6-(**)C2/R1-IDU		●		●		●		●	●	●	●	●															
Eight-way cassette	Cooling & Heating	NV6-(**)C8/R1-IDU				●		●		●	●	●	●	●	●	●	●	●	●	●									
DC inverter duct	Cooling & Heating	NV6-(**)D3RD/R1-IDU	●	●		●		●		●	●	●	●	●															
Middle static pressure	Cooling & Heating	NV6-(**)D2R/R1-IDU									●	●	●	●	●	●	●	●	●	●	●								
High static pressure	Cooling & Heating	NV6-(**)D1R/R1-IDU															●	●	●	●	●		●		●		●	●	
Wall-mounted	Cooling & Heating	NV6-(**)W/R1-IDU		●		●		●		●	●	●		●															
Fresh air duct	Cooling & Heating	NV6-(**)F1/XFN1Y(E)																								●		●	●
Ceilinging & Floor	Cooling & Heating	NV6-V(**)CF/R1-IDU															●	●	●	●									



One-way Cassette

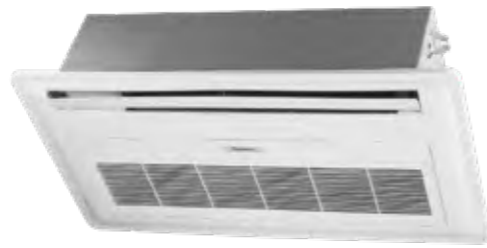

Recommended places

Living room, dining room, office, lobby, etc

Technical characteristics



High-lift Drain Pump

The drain pump with a 700mm lifting head which is as standard, simplifying installation of the drain pipes.



Standard float switch, real-time monitor water level

Equipped with float switch, which will automatically monitor the water level and send alarm when malfunction of drain pump or stuck of drain pipe occurs.



Wide-angle air flow

Adopting new type of swing motor, which largely increases the angle of air flow.



High ceiling design

Reserves a super high fan speed for high ceiling installation, unit can provide powerful cooling and heating under a more than 3 meters floor height.



Slim body

Super slim body with 235mm thickness, less installation area required, capable to match multiple decoration styles.



Suitable for corner installation, comfortable air flow

Well-designed shape, suitable for corner installation, make sure the air flow and temperature distribution well.



Three level fan speeds

High, Mid, Low three fan speed options, can meet the needs of different indoor condition.

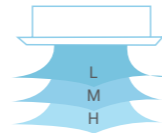

IDU parameters

HP		NV6-18C1/R1-IDU	NV6-22C1/R1-IDU	NV6-28C1/R1-IDU	NV6-36C1/R1-IDU	NV6-45C1/R1-IDU	NV6-50C1/R1-IDU	NV6-56C1/R1-IDU
Capacity	Cooling	kW	1.8	2.2	2.8	3.6	4.5	5.6
	Heating	kW	2.2	2.8	3.2	4	5	6.3
Power input	Cooling	kW	0.05	0.05	0.05	0.06	0.07	0.07
	Heating	kW	0.05	0.05	0.05	0.06	0.07	0.07
Power supply		220V ~ 1N 50Hz						
Current	Cooling	A	0.24	0.24	0.24	0.28	0.31	0.31
	Heating	A	0.24	0.24	0.24	0.28	0.31	0.31
Air volume	m³/h	510	510	510	680	800	800	800
Noise	H/M/L	dB(A)	39/34/31	39/34/31	39/34/31	40/34/31	42/36/33	42/36/33
Dimension	panel	mm	580×1055	580×1055	580×1055	580×1055	580×1055	580×1055
	unit	mm	850×480×235	850×480×235	850×480×235	850×480×235	850×480×235	850×480×235
	packing	mm	1105×645×305	1105×645×305	1105×645×305	1105×645×305	1105×645×305	1105×645×305
Weight	net	kg	23	23	23	23	23	23
	gross	kg	28	28	28	28	28	28
Connection pipe	Gas	mm	9.52	9.52	9.52	12.7	12.7	12.7
	Liquid	mm	6.35	6.35	6.35	6.35	6.35	6.35
Connection way		Screw thread						
Water pipe dimension(mm)		φ25						
Controller		Remote/Wired/Central controller						

Notes: 1. Specifications are based on the following conditions:
 2. Cooling: Indoor temperature 27°C DB/19°C WB, and outdoor temperature 35°C DB/24°C WB.
 3. Heating: Indoor temperature 20°C DB/15°C WB, and outdoor temperature 7°C DB/6°C WB.
 4. Equivalent piping length: 5m; Level difference: 0m; Voltage: 230V.

5. Sound Level: Indoor unit sound pressure level, measured at a point 1.5m downward from the unit center.
 6. Outdoor unit sound pressure level, measured at a point 1.0m in front of the unit.
 7. Optional simple wired controller; Universal remote controller; auto-restart(optional); Timer: only one circle.
 8. Due to ongoing product development, specifications are subject to change without notice.

Two-way Cassette



Recommended places

Sitting room, study, dining room, small meeting room, etc

Technical characteristics



High-lift Drain Pump

A drain pump with a 700mm raise height is fitted as standard, simplifying installation of the drain piping.



Standard float switch, water level monitor

Equipped with float switch, which will automatically send alarm when malfunction of drain pump or stuck of drain pipe occur.



Three - speed adjustment

New winding motor, with scroll fan technology, wider air volume regulation, quieter operation, unique intimate wind gear design. High, medium and low three speed adjustment, strong refrigeration and heating, to create a quiet and comfortable temperature.



Ultra-thin body, lightweight design

Ultra-thin body (290mm), requires less installation space, even in the narrow low ceiling, still can be easily installed, more flexible collocation decoration style.



Super wide Angle air supply

Panel swing motor system adopts high-precision stepper motor, panel up and down risk control system is more intelligent, to achieve ultra-wide Angle and large range of air supply.



Quiet design, quiet and comfortable

Centrifugal wind wheel, axial air inlet, through rotation to form a certain wind pressure, small blade area, large number, uniform air, noise greatly reduced, for you to create a quiet and comfortable environment.



High ceiling design, direct air flow to the ground

High ceiling design, suitable for ceiling height up to 3m space.

IDU parameters

Model	NV6-22C2/R1-IDU	NV6-28C2/R1-IDU	NV6-36C2/R1-IDU	NV6-45C2/R1-IDU	NV6-50C2/R1-IDU	NV6-56C2/R1-IDU	NV6-63C2/R1-IDU	NV6-71C2/R1-IDU
Capacity	Cooling(kW)	2.2	2.8	3.6	4.5	5	5.6	6.3
	Heating(kW)	2.8	3.2	4	5	5.6	6.3	7.1
Power input	Cooling(kW)	0.064	0.064	0.064	0.064	0.07	0.07	0.11
	heating(kW)	0.064	0.064	0.064	0.064	0.07	0.07	0.11
Power supply		220V ~ 1N 50Hz						
Current	Cooling(A)	0.27	0.27	0.27	0.27	0.31	0.31	0.49
	heating(A)	0.27	0.27	0.27	0.27	0.31	0.31	0.49
Air volume	(m³/h)	580	580	680	680	850	850	1360
Noise	H/M/L	dB(A)	40/35/32	42/36/33	42/36/33	42/36/33	42/38/35	43/38/35
Dimension	Panel(mm)	680×1240	680×1240	680×1240	680×1240	680×1240	680×1240	680×1240
	Body (mm)	1140×575×290	1140×575×290	1140×575×290	1140×575×290	1140×575×290	1140×575×290	1140×575×290
	Packing(mm)	1305×755×370	1305×755×370	1305×755×370	1305×755×370	1305×755×370	1305×755×370	1305×755×370
Weight	Net(kg)	32	32	32	32	33	33	34
	Gross(kg)	38	38	38	38	39	39	40
connection pipe	gas (mm)	12.7	12.7	12.7	12.7	12.7	12.7	15.88
	liquid(mm)	6.35	6.35	6.35	6.35	6.35	6.35	9.52
connection way		Screw thread						
Drainage pipe(mm)		φ25						
Controller		Remote/Wired/Central controller						

Notes: 1. Specifications are based on the following conditions:
 2. Cooling: Indoor temperature 27°C DB/19°C WB, and outdoor temperature 35°C DB/24°C WB.
 3. Heating: Indoor temperature 20°C DB/15°C WB, and outdoor temperature 7°C DB/6°C WB.
 4. Equivalent piping length: 5m; Level difference: 0m; Voltage: 230V.

5. Sound Level: Indoor unit sound pressure level, measured at a point 1.5m downward from the unit center.
 6. Outdoor unit sound pressure level, measured at a point 1.0m in front of the unit.
 7. Optional simple wired controller; Universal remote controller; auto-restart(optional); Timer: only one circle.
 8. Due to ongoing product development, specifications are subject to change without notice.



Eight-way Cassette

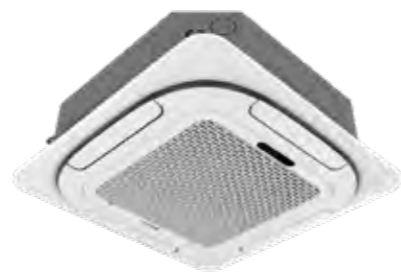

Recommended places

Office, restaurant, supermarket, shopping mall, lobby, etc

Technical characteristics



New panel design

Adopt the new design of "porcelain white" color, beautiful and generous, so that the indoor machine panel and the ceiling color more easily integrated, more noble, surround type air supply panel, air supply more comfortable.



360° wide-angle air supply

Comfortable air supply does not leave dead corner, every corner can enjoy cool; Uniform air supply, reduce the temperature difference, keep the indoor temperature comfortable; Air supply is no longer directed single, keep air circulation, air more fresh and healthy.

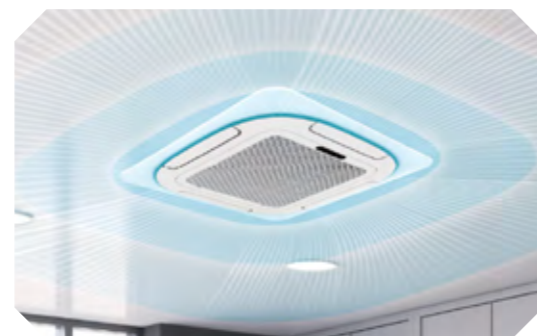

LED digital display

Real-time operating temperature and operation fault clearly display, the operating status of the unit in one hand.



Four gears, wider air volume adjustment

New winding motor, with scroll fan technology, wider air volume regulation, quieter operation, unique intimate wind gear design. Four speed regulation, strong refrigeration and heating, to create a quiet and comfortable temperature.



Thin fuselage, saving space

Thin fuselage, the installation space required is small, the unit can be easily installed in a fairly narrow ceiling.



Standard condensate pump, easy to install

Equipped with advanced high-lift condensate drainage pump, the maximum head up to 1200mm, easy to install drainpipes.



Clean sterilization, healthy life

Standard health filter screen, effectively remove large particles in the air, optional silver ion purification module, adsorption of formaldehyde and odor, eliminate germs.



High efficiency energy saving motor

Adopt high efficiency energy saving motor, motor efficiency can reach 80%, air conditioning energy saving can be increased by more than 20%.



Ultra low noise

Using the advanced technology of three-dimensional spiral blade design, can reduce the air resistance, realize the machine low noise operation, "quiet" enjoy a comfortable life.



Standard float switch, timely warning

Standard float switch, when the condensate pump is faulty or the drainpipe is blocked, timely warning, prevent the water tray inside the machine overflow.

Eight-way Cassette

NV6-***C8/R1-IDU		NV6-28C8/R1-IDU	NV6-36C8/R1-IDU	NV6-45C8/R1-IDU	NV6-50C8/R1-IDU	NV6-56C8/R1-IDU	NV6-63C8/R1-IDU	NV6-71C8/R1-IDU	NV6-80C8/R1-IDU	NV6-90C8/R1-IDU	NV6-100C8/R1-IDU	NV6-112C8/R1-IDU	NV6-125C8/R1-IDU	NV6-140C8/R1-IDU		
Capacity	Cooling capacity	kW	2.8	3.6	4.5	5	5.6	6.3	7.1	8	9	10	11.2	12.5	14	
	Heating capacity	kW	3.2	4	5	5.6	6.3	7.1	8	9	10	11.2	12.5	14	16	
Power	Cooling power	kW	0.08	0.08	0.08	0.08	0.08	0.1	0.1	0.1	0.15	0.15	0.15	0.18	0.18	
	Heating power	kW	0.08	0.08	0.08	0.08	0.08	0.1	0.1	0.1	0.15	0.15	0.15	0.18	0.18	
Power supply		220V ~ 1N 50Hz														
Current	Cooling current	A	0.36	0.36	0.36	0.36	0.36	0.45	0.45	0.45	0.68	0.68	0.68	0.82	0.82	
	Heating current	A	0.36	0.36	0.36	0.36	0.36	0.45	0.45	0.45	0.68	0.68	0.68	0.82	0.82	
Fan	air volume	m³/h	850	850	850	850	850	1100	1100	1100	1500	1500	1500	1800	1800	
External static pressure	Pa	0	0	0	0	0	0	0	0	0	0	0	0	0	0	
Outdoor noise level	dB(A)	37/35/33	37/35/33	37/35/33	37/35/33	37/35/33	39/36/33	39/36/33	39/36/33	43/40/35	43/40/35	43/40/35	48/45/41	48/45/41		
Connecting pipe diameter	gas pipe	mm	12.7						15.88							
	liquid tube	mm	6.35						9.52							
	Connection mode	/	Threaded connection													
Net dimension(L×W×H)	mm	840×840×245											840×840×290			
Weight	Net weight	kg	22	22	22	22	22	24	24	24	26.5	26.5	26.5	28	28	
	Panel size	mm	950×950×50													
Panel	Net weight	kg	6													
	Drainage pipe diameter		DN32													
Electric control mode		Remote Controller & Wired controller														

Specification

NV6-***C8/R1-IDU		NV6-28C8/R1-IDU	NV6-36C8/R1-IDU	NV6-45C8/R1-IDU	NV6-50C8/R1-IDU	NV6-56C8/R1-IDU	NV6-63C8/R1-IDU	NV6-71C8/R1-IDU	NV6-80C8/R1-IDU	NV6-90C8/R1-IDU	NV6-100C8/R1-IDU	NV6-112C8/R1-IDU	NV6-125C8/R1-IDU	NV6-140C8/R1-IDU		
Capacity	Cooling capacity	kW	2.8	3.6	4.5	5	5.6	6.3	7.1	8	9	10	11.2	12.5	14	
	Heating capacity	kW	3.2+0.8	4.0+0.8	5.0+0.8	5.6+0.8	6.3+0.8	7.1+2.1	8.0+2.1	9.0+2.1	10.0+2.1	11.2+2.1	12.5+2.1	14.0+2.1	16.0+2.1	
Power	Cooling power	kW	0.08	0.08	0.08	0.08	0.08	0.1	0.1	0.1	0.15	0.15	0.15	0.18	0.18	
	Heating power	kW	0.08+0.8	0.08+0.8	0.08+0.8	0.08+0.8	0.08+0.8	0.1+2.1	0.1+2.1	0.1+2.1	0.15+2.1	0.15+2.1	0.15+2.1	0.18+2.1	0.18+2.1	
Power supply		220V ~ 1N 50Hz														
Current	Cooling current	A	0.36	0.36	0.36	0.36	0.36	0.45	0.45	0.45	0.68	0.68	0.68	0.82	0.82	
	Heating current	A	0.36+3.6	0.36+3.6	0.36+3.6	0.36+3.6	0.36+3.6	0.45+9.5	0.45+9.5	0.45+9.5	0.68+9.5	0.68+9.5	0.68+9.5	0.82+9.5	0.82+9.5	
Fan	air volume	m³/h	850	850	850	850	850	1100	1100	1100	1500	1500	1500	1800	1800	
External static pressure	Pa	0	0	0	0	0	0	0	0	0	0	0	0	0		
Outdoor noise level	dB(A)	37/35/33	37/35/33	37/35/33	37/35/33	37/35/33	39/36/33	39/36/33	39/36/33	43/40/35	43/40/35	43/40/35	48/45/41	48/45/41		
Connecting pipe diameter	gas pipe	mm	12.7						15.88							
	liquid tube	mm	6.35						9.52							
	Connection mode	/	Threaded connection													
Net dimension(L×W×H)	mm	840×840×245											840×840×290			
Weight	Net weight	kg	23	23	23	23	25	25	25	27.5	27.5	27.5	29	29	28	
	Panel size	mm	950×950×50													
Panel	Net weight	kg	6													
	Drainage pipe diameter		DN32													
Electric control mode		Remote Controller & Wired controller														

Notes: 1. Specifications are based on the following conditions:
 2. Cooling: Indoor temperature 27°C DB/19°C WB, and outdoor temperature 35°C DB/24°C WB.
 3. Heating: Indoor temperature 20°C DB/15°C WB, and outdoor temperature 7°C DB/6°C WB.
 4. Equivalent piping length:5m; Level difference:0m; Voltage:230V.

5. Sound Level: Indoor unit sound pressure level, measured at a point 1.5m downward from the unit center.
 6. Outdoor unit sound pressure level, measured at a point 1.0m in front of the unit.
 7. Optional simple wired controller; Universal remote controller; auto-restart(optional); Timer: only one circle.
 8. Due to ongoing product development, specifications are subject to change without notice.



DC Series Slim Duct



Recommended places

Office, conference room, hotel room, restaurant, living room, etc

Specification



Dc seven speed wind speed Energy-saving silent operation DC motor, 7-speed air volume, energy-saving and silent operation. The lowest noise is 22 d B(A).



Health filter (optional)

The duct can be equipped with silver ion and activated carbon health filter.

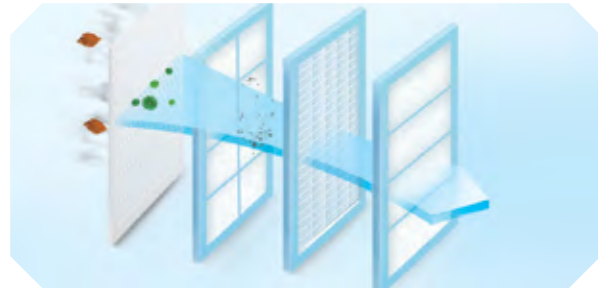

Constant air volume

Fan motor automatically adjusts speed according to realtime wind resistance. To provide stable air volume to rooms.



Ultra-thin body design, fashion and beautiful

The minimum height of the body is only 200mm, saving space.

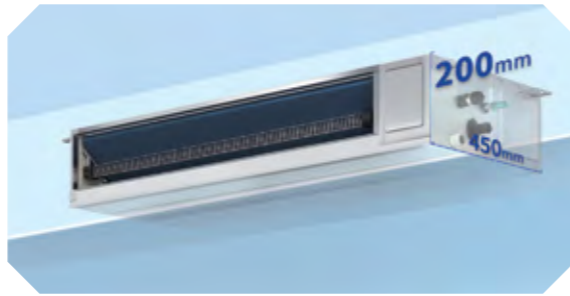

Standard float switch, timely warning

Standard float switch, when the condensate pump is faulty or the drainpipe is blocked, timely warning, prevent the water tray inside the machine overflow.



Humanized return air mode selection, flexible installation

It is optional to have air inlet form back or bottom with the same size of plate, which will be very flexible and convenient for installation.



High ESP

ESP up to 80Pa supports longer air duct and fits with more installation scenario.

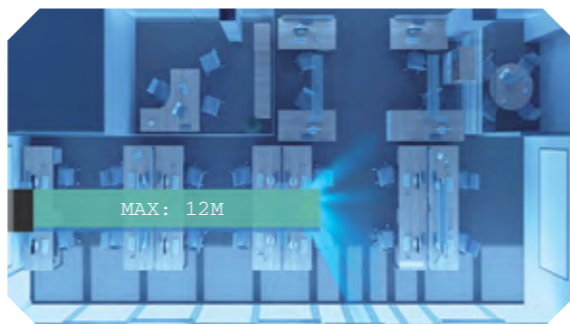

Technical characteristics

Model		NV6-18D3RD/R1-IDU	NV6-22D3RD/R1-IDU	NV6-25D3RD/R1-IDU	NV6-28D3RD/R1-IDU	NV6-32D3RD/R1-IDU	NV6-36D3RD/R1-IDU	NV6-40D3RD/R1-IDU	NV6-45D3RD/R1-IDU	NV6-50D3RD/R1-IDU	NV6-56D3RD/R1-IDU		
Capacity	Cooling capacity	kW	1.8	2.2	2.5	2.8	3.2	3.6	4.0	4.5	5.0	5.6	
	Heating capacity	kW	2.2	2.5	2.8	3.2	3.6	4.0	4.5	5.0	5.6	6.3	
Power	Cooling power	kW	0.02	0.02	0.02	0.02	0.03	0.03	0.05	0.05	0.05	0.05	
	Heating power	kW	0.02	0.02	0.02	0.02	0.03	0.03	0.05	0.05	0.05	0.05	
Power supply			220V 1N~50Hz										
Current	Cooling current	A	0.09	0.09	0.09	0.09	0.14	0.14	0.23	0.23	0.23	0.23	
	Heating current	A	0.09	0.09	0.09	0.09	0.14	0.14	0.23	0.23	0.23	0.23	
Fan	Air volume	m³/h	500	500	500	500	550	550	850	850	850	850	
External static pressure	Pa	20(0 ~ 50)	20(0 ~ 50)	20(0 ~ 50)	20(0 ~ 50)	20(0 ~ 50)	20(0 ~ 50)	20(0 ~ 50)	20(0 ~ 50)	20(0 ~ 50)	20(0 ~ 50)	20(0 ~ 50)	
Noise H/M/L	dB(A)	30/26/20	30/26/20	30/26/20	30/26/20	30/26/22	30/26/22	34/29/24	34/29/24	34/29/24	34/29/24	34/29/24	
Net dimension (L×W×H)	Net dimensions	mm	700×450×200						920×450×200				
	Size of return air inlet	mm	570×172						790×172				
	Air outlet size	mm	510×140						730×140				
Net weight	kg	14.5	14.5	14.5	14.5	14.5	14.5	17.0	17.0	17.0	17.0		
Connecting pipe diameter	gas pipe	mm	9.52	9.52	9.52	9.52	12.70	12.70	12.70	12.70	12.70	12.70	
	liquid tube	mm	6.35	6.35	6.35	6.35	6.35	6.35	6.35	6.35	6.35	6.35	
	Connection mode	/	Threaded connection										
Drainage pipe diameter	mm	DN25											
Electric control mode	/	Remote Controller & Wired controller											

Model		NV6-63D3RD/R1-IDU	NV6-71D3RD/R1-IDU	NV6-80D3RD/R1-IDU	NV6-90D3RD/R1-IDU	NV6-100D3RD/R1-IDU	NV6-112D3RD/R1-IDU	NV6-125D3RD/R1-IDU	NV6-140D3RD/R1-IDU		
Capacity	Cooling capacity	kW	6.3	7.1	8.0	9.0	10.0	11.2	12.5	14.0	
	Heating capacity	kW	7.1	8.0	9.0	10.0	11.2	12.5	14.0	16.0	
Power	Cooling power	kW	0.054	0.054	0.054	0.180	0.180	0.180	0.250	0.250	
	Heating power	kW	0.054	0.054	0.054	0.180	0.180	0.180	0.250	0.250	
Power supply			220V 1N~50Hz								
Current	Cooling current	A	0.25	0.25	0.25	0.90	0.90	0.90	1.20	1.20	
	Heating current	A	0.25	0.25	0.25	0.90	0.90	0.90	1.20	1.20	
Fan	air volume	m³/h	1100	1100	1100	1800	1800	1800	2000	2000	
External static pressure	Pa	20(0 ~ 80)	20(0 ~ 80)	20(0 ~ 80)	60(30 ~ 80)	60(30 ~ 80)	60(30 ~ 80)	60(30 ~ 80)	60(30 ~ 80)	60(30 ~ 80)	
Noise H/M/L	dB(A)	37/31/27	37/31/27	37/31/27	43/37/33	43/37/33	43/37/33	44/41/37	44/41/37	44/41/37	
Net dimension (L×W×H)	Net dimensions	mm	1100×450×200				1400×700×250				
	Size of return air inlet	mm	1004×165				1365×220				
	Air outlet size	mm	930×140				1365×175				
Net weight	kg	21.5	21.5	21.5	35.5	35.5	35.5	37.5	37.5		
Connecting pipe diameter	gas pipe	mm	15.88	15.88	15.88	15.88	15.88	15.88	15.88	15.88	
	liquid tube	mm	9.52	9.52	9.52	9.52	9.52	9.52	9.52	9.52	
	Connection mode	/	Threaded connection								
Drainage pipe diameter	mm	DN25									
Electric control mode	/	Remote Controller & Wired controller									

Notes: 1. Specifications are based on the following conditions:
 2. Cooling: Indoor temperature 27°C DB/19°C WB, and outdoor temperature 35°C DB/24°C WB.
 3. Heating: Indoor temperature 20°C DB/15°C WB, and outdoor temperature 7°C DB/6°C WB.
 4. Equivalent piping length:5m; Level difference:0m; Voltage:230V.

5. Sound Level: Indoor unit sound pressure level,measured at a point 1.5m downward from the unit center.
 6. Outdoor unit sound pressure level,measured at a point 1.0m in front of the unit.
 7. Optional simple wired controller; Universal remote controller; auto-restart(optional); Timer:only one circle.
 8. Due to ongoing product development, specifications are subject to change without notice.



Medium static pressure Duct

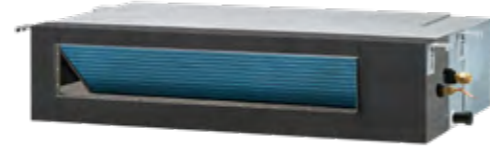

Recommended places
Office, conference room, exhibition hall, restaurant, etc

Technical characteristics



Flexible to adapt to a variety of room structure
It is optional to have air inlet form back or bottom with the same size of plate ,which will be very flexible and convenient for installation.



Built-in drain pump(optional).
The drain pump can lift the condensing water up to 1200mm.



Ultra-thin body design, fashion and beautiful
The minimum height of the body is only 200mm, saving space.



Personalized tuynet
Suitable tuynet can be assembled to make the air conditioning decoration style perfect integration, highlighting the taste of the room.



Flexible installation
The factory standard bellows, according to the installation needs, can be adjusted on site under or after the return air, to meet the needs of different installation sites.

Specification

Model		NV6-63D2R/R1-IDU	NV6-71D2R/R1-IDU	NV6-80D2R/R1-IDU	NV6-90D2R/R1-IDU	NV6-100D2R/R1-IDU	NV6-112D2R/R1-IDU	NV6-125D2R/R1-IDU	NV6-140D2R/R1-IDU	
Capacity	Cooling capacity	kW	6.3	7.1	8	9	10	11.2	12.5	14
	Heating capacity	kW	7.1+1	8+1	9+1	10+2	11.2+2	12.5+2	14+3.5	16+3.5
Power	Cooling power	kW	0.16	0.16	0.16	0.33	0.33	0.33	0.39	0.39
	Heating power	kW	0.16+1	0.16+1	0.16+1	0.33+2	0.33+2	0.33+2	0.39+3.5	0.39+3.5
Power supply			220V 1N~50HZ				380V 3N~50HZ			
Current	Cooling current	A	0.74	0.74	0.74	1.5	1.5	1.5	1.78	1.78
	Heating current	A	0.74+4.5	0.74+4.5	0.74+4.5	1.5+9.1	1.5+9.1	1.5+9.1	1.78+4.6	1.78+4.6
Fan	air volume	(m³/h)	1100	1100	1100	1700	1700	1700	2200	2200
External static pressure		Pa	30(20~50)	30(20~50)	30(20~50)	50(30~80)	50(30~80)	50(30~80)	50(30~100)	50(30~100)
Outdoor noise level		dB(A)	46/37/35	46/37/35	46/37/35	50/44/41	50/44/41	50/44/41	54/46/43	54/46/43
Net dimension (L×W×H)	Unit size	mm	920×570×270	920×570×270	920×570×270	1140×710×270	1140×710×270	1140×710×270	1200×800×300	1200×800×300
	Size of return air inlet	mm	816×270	816×270	816×270	1035×270	1035×270	1035×270	1094×300	1094×300
	Air outlet size	mm	713×179	713×179	713×179	933×179	933×179	933×179	968×204	968×204
Weight	Net weight	kg	28	28	28	38	38	38	48	48
	gas pipe	mm	15.88	15.88	15.88	15.88	15.88	15.88	15.88	15.88
Connecting pipe diameter	liquid tube	mm	9.52	9.52	9.52	9.52	9.52	9.52	9.52	9.52
	Connection mode	/	Threaded connection							
Drainage pipe diameter		mm	DN25							
Electric control mode			Remote Controller & Wired controller							

Notes: 1. Specifications are based on the following conditions:
2. Cooling: Indoor temperature 27°C DB/19°C WB, and outdoor temperature 35°C DB/24°C WB.
3. Heating: Indoor temperature 20°C DB/15°C WB, and outdoor temperature 7°C DB/6°C WB.
4. Equivalent piping length:5m; Level difference:0m; Voltage:230V.

5. Sound Level: Indoor unit sound pressure level,measured at a point 1.5m downward from the unit center.
6. Outdoor unit sound pressure level,measured at a point 1.0m in front of the unit.
7. Optional simple wired controller; Universal remote controller; auto-restart(optional); Timer:only one circle.
8. Due to ongoing product development, specifications are subject to change without notice.

High static pressure Duct



Recommended places
Workshop, hotel, restaurant, shopping mall, ballroom, bar and other large space places

Technical characteristics



Healthy new wind, forest breathing
Easy introduction of outdoor fresh air heating refrigeration and indoor air exchange, keep indoor air fresh, bring you comfortable fresh air.



Ultra-thin body design, fashion and beautiful
The minimum thickness of the fuselage is only 380mm, which does not occupy indoor space.



Pa
Ultra-high static pressure design to meet various space requirements
Maximum static pressure 300Pa, can be long distance multi-point air supply, fully meet the air conditioning needs of different Spaces.



Clean sterilization, healthy life
Built-in coarse filter, PP filter screen, optional silver ion purification module, effectively remove large particles in the air, absorb formaldehyde and odor, eliminate germs.



Various forms of air outlets,matching with decoration
The indoor unit adopts a hidden installation mode, which can be equipped with appropriate air outlets to perfectly combine the air conditioning.



Specification

Model		NV6-71D1R/R1-IDU	NV6-112D1R/R1-IDU	NV6-140D1R/R1-IDU	
Static pressure	Standard	Pa	100	100	130
	Range	Pa	50~130	50~130	50~130
Cooling capacity	Capacity	Btu/h(W)	24000 (7100)	38000 (11200)	48000 (14000)
	Input	W	280	420	420
Heating capacity	Capacity	Btu/h(W)	27000 (8000)	42000 (12500)	55000 (16000)
	Input	W	280	420	420
Noise	H/M/L	dB(A)	50/48/46	53/51/49	53/51/49
Design pressure		MPa	4.1	4.1	4.1
Power supply			220-240V~/50Hz/60Hz		
Indoor air circulation (Cooling/Heating)	L/S		350	561	639
	m³/h		1260	2020	2300
Connecting Pipe	Liquid	Inches	3/8"	3/8"	3/8"
	Gas	Inches	5/8"	5/8"	5/8"
Drainage Pipe		mm	25(D20,OD25)		
Net dimensions		W x H x D	mm	850×380×590	1200×380×590
Net weight		kg	49	58	58
Packing dimensions		W x H x D	mm	1060×425×695	1410×435×695
Gross weight		kg	55	64	64
Loading Capacity			2.5HP	4.0HP	5.0HP
Controller			Remote Controller & Wired controller		

Notes: 1. Specifications are based on the following conditions:
2. Cooling: Indoor temperature 27°C DB/19°C WB, and outdoor temperature 35°C DB/24°C WB.
3. Heating: Indoor temperature 20°C DB/15°C WB, and outdoor temperature 7°C DB/6°C WB.
4. Equivalent piping length:5m; Level difference:0m; Voltage:230V.

5. Sound Level: Indoor unit sound pressure level,measured at a point 1.5m downward from the unit center.
6. Outdoor unit sound pressure level,measured at a point 1.0m in front of the unit.
7. Optional simple wired controller; Universal remote controller; auto-restart(optional); Timer:only one circle.
8. Due to ongoing product development, specifications are subject to change without notice.



Wall mounted



Recommended places

Living room, study, reference room, negotiation room and other places



Wide-angle air supply, more comfortable

The upper and lower wind guide vanes make the airflow comfortable.

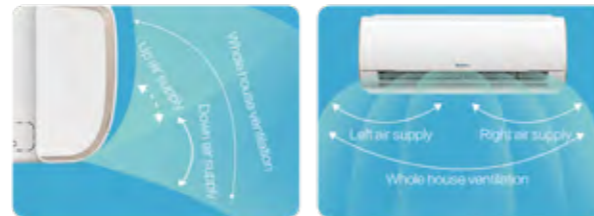

Technical characteristics



Ultra-low silent operation

Adopt large-diameter blade, high-quality plastic-encapsulated motor, and the noise is as low as 27dB(A).



Ultra-thin body design, smart and beautiful

The minimum thickness of the unit is only 380mm, which makes installation more convenient.



Easy maintenance

The horizontal baffle of the unit is easy to remove for easy cleaning and maintenance.



Long-lasting filter design

The long-term filter design makes the air more healthy, reduces the difficulty of maintenance.

Specification

Model			NV6-22W/R1-IDU	NV6-28W/R1-IDU	NV6-36W/R1-IDU	NV6-45W/R1-IDU	NV6-50W/R1-IDU	NV6-56W/R1-IDU	NV6-71W/R1-IDU	NV6-80W/R1-IDU
Cooling capacity	Capacity	Btu/h(W)	7500(2200)	10000(2800)	12000(3600)	15000(4500)	17000(5000)	19000(5600)	24000(7100)	27000(8000)
	Input	W	40	40	40	45	45	70	70	70
Heating capacity	Capacity	Btu/h(W)	9000(2500)	11000(3200)	14000(4000)	17000(5000)	19000(5600)	21000(6300)	27000(8000)	30000(9000)
	Input	W	40	40	40	45	45	70	70	70
Noise	H/M/L	dB(A)	38/33/27	38/33/27	38/33/27	42/37/33	42/37/33	44/39/35	44/39/35	44/39/35
Design pressure		MPa	4.1	4.1	4.1	4.1	4.1	4.1	4.1	4.1
Power supply			220-240V~/50Hz 208-230V~/60Hz	220-240V~/50Hz 208-230V~/60Hz	220-240V~/50Hz 208-230V~/60Hz	220-240V~/50Hz 208-230V~/60Hz	220-240V~/50Hz 208-230V~/60Hz	220-240V~/50Hz 208-230V~/60Hz	220-240V~/50Hz 208-230V~/60Hz	220-240V~/50Hz 208-230V~/60Hz
Indoor air circulation(Cooling/Heating)	L/S		153	153	153	181	181	222	222	222
	m³/h		550	550	550	650	650	800	800	800
Connecting Pipe	Liquid	Inches	1/4"	1/4"	1/4"	1/4"	1/4"	3/8"	3/8"	3/8"
	Gas	Inches	1/2"	1/2"	1/2"	1/2"	1/2"	5/8"	5/8"	5/8"
Drainage Pipe		mm	16	16	16	16	16	16	16	16
Net dimensions	(W x H x D)	mm	910×294×206	910×294×206	910×294×206	910×294×206	910×294×206	1010×315×220	1010×315×220	1010×315×220
Net weight	Indoor	kg	10	10	10	10	10	13	13	13
Packing dimensions	(W x H x D)	mm	977×367×276	977×367×276	977×367×276	977×367×276	977×367×276	1094×386×300	1094×386×300	1094×386×300
Gross weight		kg	12.5	12.5	12.5	12.5	12.5	16	16	16
Loading Capacity			0.9HP	1.0HP	1.2HP	1.5HP	1.8HP	2.0HP	2.0HP	2.0HP
Controller			Remote Controller & Wired controller							

Notes: 1. Specifications are based on the following conditions:
 2. Cooling: Indoor temperature 27°C DB/19°C WB, and outdoor temperature 35°C DB/24°C WB.
 3. Heating: Indoor temperature 20°C DB/15°C WB, and outdoor temperature 7°C DB/6°C WB.
 4. Equivalent piping length:5m; Level difference:0m; Voltage:230V.

5. Sound Level: Indoor unit sound pressure level, measured at a point 1.5m downward from the unit center.
 6. Outdoor unit sound pressure level, measured at a point 1.0m in front of the unit.
 7. Optional simple wired controller; Universal remote controller; auto-restart(optional); Timer: only one circle.
 8. Due to ongoing product development, specifications are subject to change without notice.

Ceiling & floor



Recommended places

Living room, study, reference room, negotiation room and other places



Ultra-thin Design

Compact design which fits for various room styles.



Wide Range of Air Flow

The air supply angle is from 0 to 110°, making the indoor temperature more uniform and more comfortable.



Dual Direction of Drainage

Condensing water can be drained both from left and right side.



Detachable Plastic Blowers

Universal designed parts and assemblies applied, which is easy for maintenance.



Flexible Installation

Two ways of installation available, ceiling suspended and floor standing.



Wire Control (optional)

Wire control is available, especially for hotel rooms, offices, etc.

Specification

Model			NV6-45CF/R1-IDU	NV6-50CF/R1-IDU	NV6-56CF/R1-IDU	NV6-63CF/R1-IDU	NV6-71CF/R1-IDU	NV6-80CF/R1-IDU	NV6-90CF/R1-IDU	NV6-100CF/R1-IDU	NV6-112CF/R1-IDU	NV6-125CF/R1-IDU	NV6-140CF/R1-IDU		
Cooling capacity	Capacity	Btu/h (W)	15000 (4500)	17000 (5000)	19000 (5600)	21000 (6300)	24000 (7100)	27000 (8000)	30000(9000)	34000 (10000)	38000(11200)	42000 (12500)	48000 (14000)		
	Input	W	102	102	102	149	149	149	158	158	235	235	235		
Heating capacity	Capacity	Btu/h (W)	17000 (5000)	19000 (5600)	21000 (6300)	24000 (7100)	27000 (8000)	30000 (9000)	34000 (10000)	38000 (11200)	42000 (12500)	48000 (14000)	55000 (16000)		
	Input	W	102	102	102	149	149	149	158	158	235	235	235		
Noise	H/M/L	dB(A)	44/42/39	44/42/39	44/42/39	46/44/41	46/44/41	46/44/41	50/48/45	50/48/45	52/50/47	52/50/47	52/50/47		
Design pressure		MPa	4.1	4.1	4.1	4.1	4.1	4.1	4.1	4.1	4.1	4.1	4.1		
Power supply			220-240V~/50Hz/												
Indoor air circulation (Cooling/Heating)	L/S		267	267	267	333	333	333	444	444	556	556	556		
	m³/h		960	960	960	1200	1200	1200	1600	1600	2000	2000	2000		
Connecting Pipe	Liquid	Inches	1/4"	1/4"	1/4"	3/8"	3/8"	3/8"	3/8"	3/8"	3/8"	3/8"	3/8"		
	Gas	Inches	1/2"	1/2"	1/2"	5/8"	5/8"	5/8"	5/8"	5/8"	5/8"	5/8"	5/8"		
Drainage Pipe		mm	25(ID20,OD25)												
Net dimensions	(W x H x D)	mm	1055×675×235						1275×675×235			1635×675×235			
Net weight		kg	24	24	24	25	25	25	29	29	38	38	38		
Packing dimensions	(W x H x D)	mm	1131×753×313						1351×753×313			1711×753×313			
Gross weight		kg	27	27	27	28	28	28	35	35	46	46	46		
Loading Capacity			1.5HP	1.8HP	2.0HP	2.2HP	2.5HP	3.0HP	3.2HP	3.6HP	4.0HP	4.5HP	5.0HP		
Controller			Remote Controller & Wired controller												

Notes: 1. Specifications are based on the following conditions:
 2. Cooling: Indoor temperature 27°C DB/19°C WB, and outdoor temperature 35°C DB/24°C WB.
 3. Heating: Indoor temperature 20°C DB/15°C WB, and outdoor temperature 7°C DB/6°C WB.
 4. Equivalent piping length:5m; Level difference:0m; Voltage:230V.

5. Sound Level: Indoor unit sound pressure level, measured at a point 1.5m downward from the unit center.
 6. Outdoor unit sound pressure level, measured at a point 1.0m in front of the unit.
 7. Optional simple wired controller; Universal remote controller; auto-restart(optional); Timer: only one circle.
 8. Due to ongoing product development, specifications are subject to change without notice.



Fresh Air Processing Unit



Recommended places
Cinemas, hotels, lobbies, dance halls, bars and other places

Technical characteristics



Healthy Fresh Air
Through the fresh air unit, the outdoor healthy air can be introduced into the room to keep the indoor healthy.



Ultra-high static pressure design
The maximum static pressure is 300pa, which can meet long-distance air supply and different space requirements.



Control Smart and Lower Cost
The fresh air unit can be controlled independently or connected to the same outdoor unit system with the AC indoor unit, reducing costs and installation space.



Simplify air exhaust system
Simplified air supply and exhaust system, stable and reliable.

Note: The sum of the capacity of the processing unit and the indoors should be 50%~100% of the ODU capacity, and the capacity of the fresh air units does not exceed 30%.



Specification

Model			NV6-140XF/R1-IDU	NV6-280XF/R1-IDU	NV6-450XF/R1-IDU	NV6-560XF/R1-IDU
Static pressure	Standard	Pa	196	200	300	300
	Capacity	Btu/h(W)	48000(14000)	95500(28000)	153000(45000)	191000(56000)
Cooling capacity	Input	W	420	1100	1550	2250
	Capacity	Btu/h(W)	34000(10000)	68000(20000)	95500(28000)	133000(39000)
Heating capacity	Input	W	420	1100	1550	2250
	H/M/L	dB(A)	45	53	56	60
Design pressure		MPa	4.1	4.1	4.1	4.1
Power supply			220-240V~/50Hz/60Hz			
Indoor air circulation (Cooling/Heating)		L/S	569	833	1111	1667
		m ³ /h	2050	3000	4000	6000
Connecting Pipe	Liquid	Inches	3/8"	1/2"	1/2"	1/2"
	Gas	Inches	5/8"	1"	9/8"	9/8"
Drainage Pipe		mm	25(ID20,OD25)			
Net dimensions	W x H x D	mm	1200×380×590	1366×470×758	1770×650×758	1770×650×758
Net weight		kg	58	120	220	220
Packing dimensions	W x H x D	mm	1410×435×695	1620×930×975	2035×1170×975	2035×1170×975
Gross weight		kg	60	145	245	245
Loading Capacity			5HP	10HP	15HP	20HP
Controller			Remote Controller & Wired controller			

- Notes:
- Specifications are based on the following conditions:
 - Cooling: Indoor temperature 27°C DB/19°C WB, and outdoor temperature 35°C DB/24°C WB.
 - Heating: Indoor temperature 20°C DB/15°C WB, and outdoor temperature 7°C DB/6°C WB.
 - Equivalent piping length:5m; Level difference:0m; Voltage:230V.
 - Sound Level: Indoor unit sound pressure level, measured at a point 1.5m downward from the unit center.
 - Outdoor unit sound pressure level, measured at a point 1.0m in front of the unit.
 - Optional simple wired controller, Universal remote controller, auto-restart(optional), Timer:only one circle.
 - Due to ongoing product development, specifications are subject to change without notice.



Location of refrigerant pipes

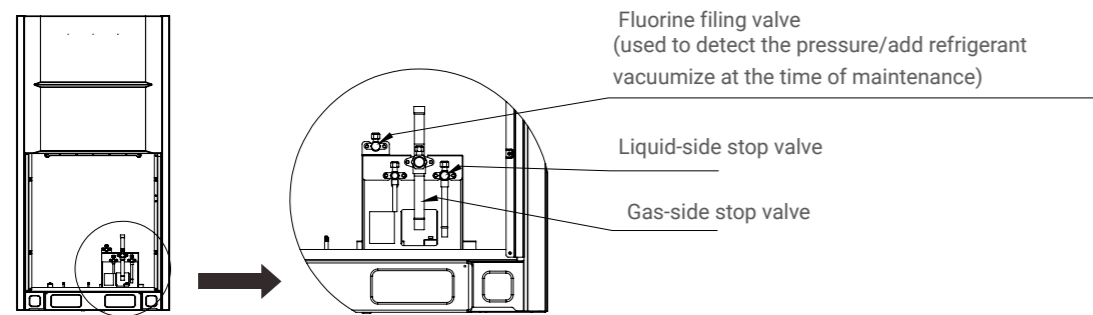

Installation space for ODU

- The space shown in the figure needs to be reserved for the installation of the ODU, and the power supply equipment should be installed separately.

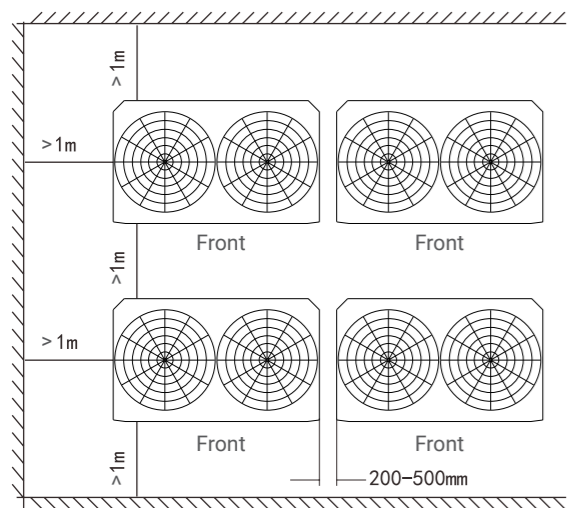

- To ensure the heat dissipation of the outdoor unit, there should be no obstacles above the outdoor unit. If it cannot be avoided, a deflector should be installed.

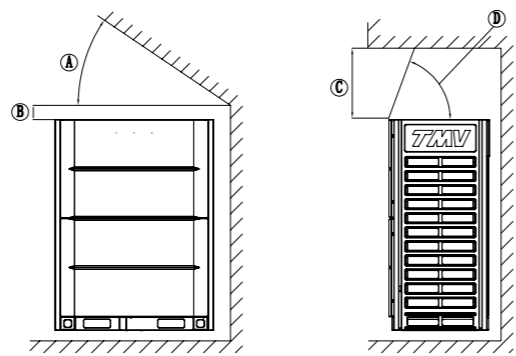

- If there are stacks around the outdoor unit, the height should be less than 800mm from the top of the outdoor unit. If it is less than the size, a mechanical exhaust device must be installed.

Arrangement sequence of ODU

- When a system has more than two outdoor units, it is necessary to install the units as the followings:
The outdoor units are arranged in descending order (for example, in the right picture, ODU capacity A ≥ ODU capacity B ≥ ODU capacity C) and the ODU A should install at the brance pipe.

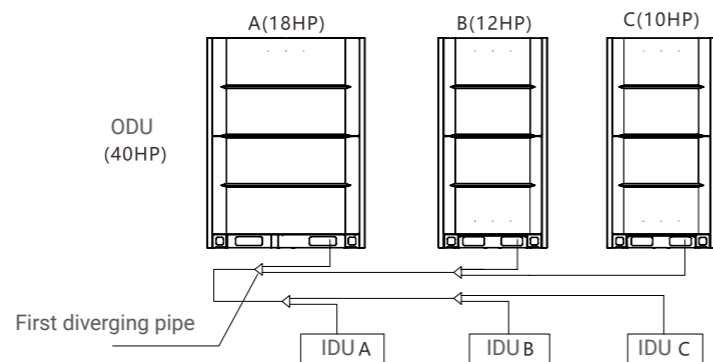

Dimension of ODU

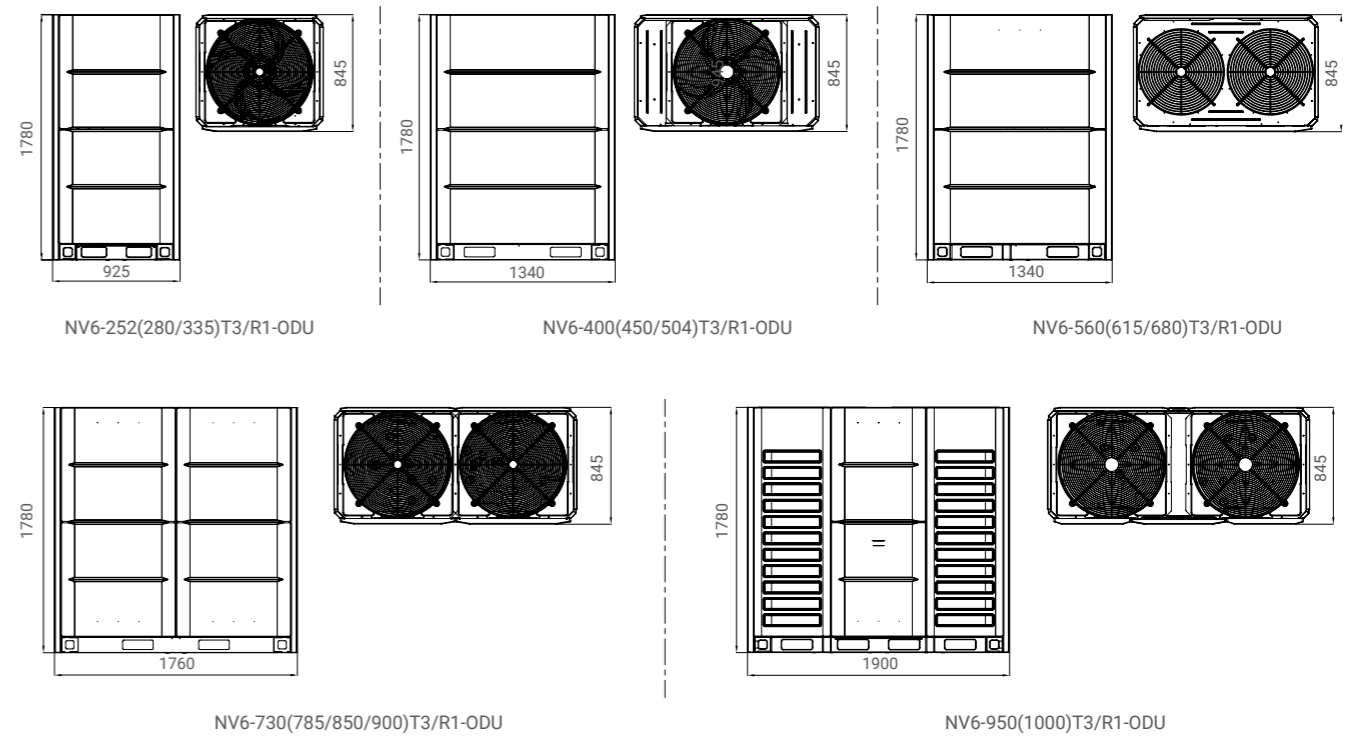

Requirements for ODU installation

- A shock absorber or shock pad should be installed between the unit and the foundation.
- The unit and the foundation should be released tightly, otherwise there will be a lot of noise and vibration.
- The outdoor unit must be grounded reliably.
- It is forbidden to open the valves of the liquid pipe, gas pipe and oil balance pipe of the unit before commission.
- The installation should ensure that there is enough space for maintenance.

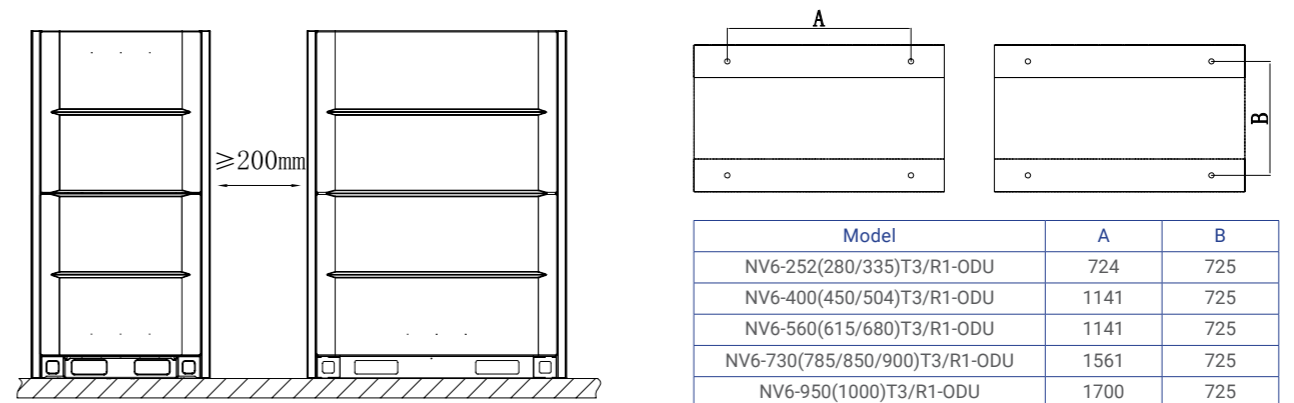



Design of refrigerant piping

Refrigerant pipe length and height

		Admissible value	Pipes
Length of supporting pipe	Total length of Refrigerant pipes (Total extended length)	1100m	$L1+(L2+L3+L4+L5+L6+L7+L8+L9+L10+L11+L12) \times 2 + a+b+c+d+e+f+g+h+i+j+k+l+m$
	Length of the farthest supporting pipe(L)	True length	220m
		Equivalent length	240m
Length of the supporting pipe furthest from the first branch pipe(L)*		120m	$L7+L8+L9+L10+i$
Height	Height difference between indoor and outdoor units (H)	ODU up	100m
		ODU down	110m
	Height between indoor units (h)		40m

* Note: Refer to relevant technical documents or consult technical person

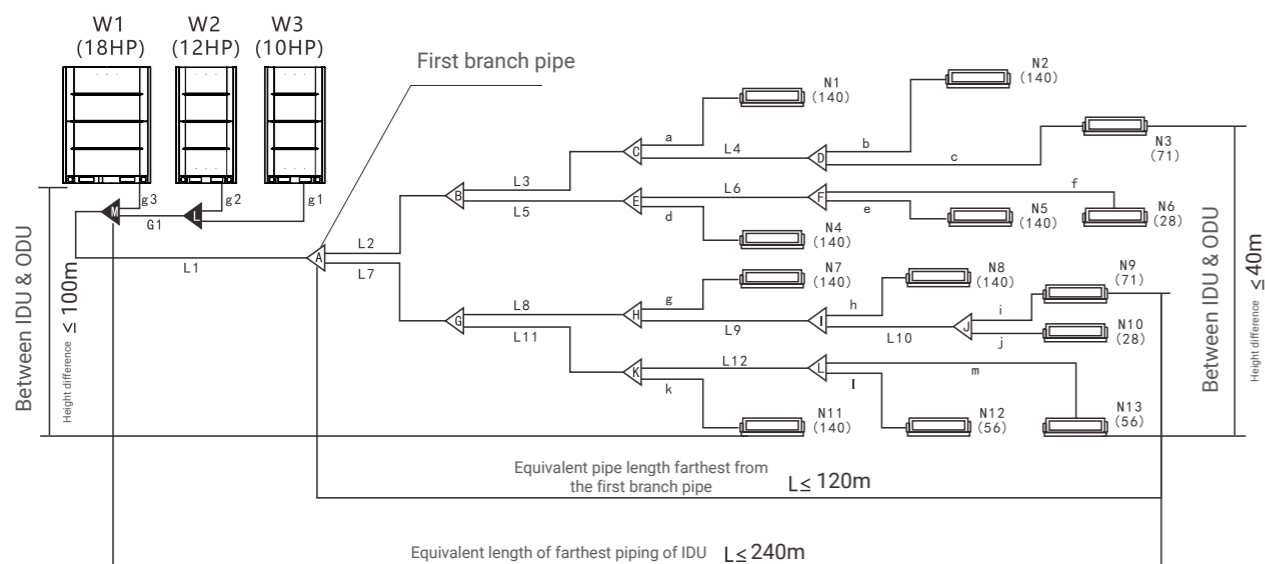

Branch pipe specifications

Assembly	Include parts	Assembly	Include parts
BY01 Branch pipe parts	G01, L01	BY05 Branch pipe parts	G04, L03
BY02 Branch pipe parts	G02, L01	BY06 Branch pipe parts	L01, L01
BY03 Branch pipe parts	G02, L02	BY07 Branch pipe parts	L01, L02
BY04 Branch pipe parts	G03, L02	BY08 Branch pipe parts	G05, G02

Branch pipe specifications

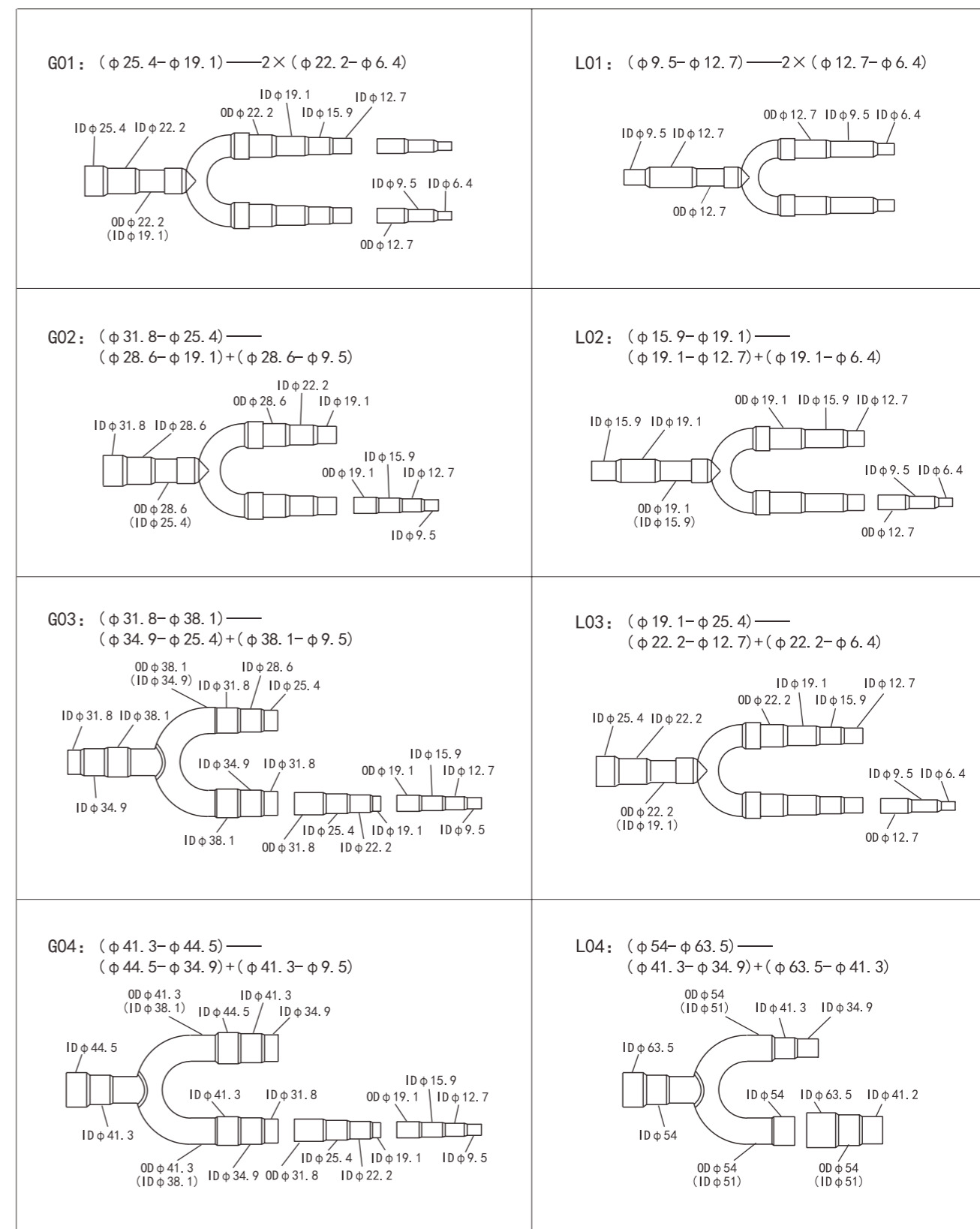



Piping classification

Allowable length and height difference of refrigerant piping

Name of supporting pipe	Connection position of supporting pipe	Assembly
Main pipe	Pipe between the outdoor unit and the first branch	L1
Main pipe of indoor unit	Pipe behind the first indoor branch which do not connect to indoor unit	L2,L3,L4,... L12
Slave pipe of indoor unit	Pipes between the branch and indoor unit	a,b, c, d,... m
Indoor unit branch assembly	Pipes to the master pipe and slave pipes	A, B, C, D, E, F, G, H, I, J, K, L
Outdoor unit branch assembly	Pipes to the outdoor unit and main pipe	L, Mg
Outdoor unit connecting pipe	Pipe between outdoor and outdoor branch	1, g2, g3, g4, G1, G2

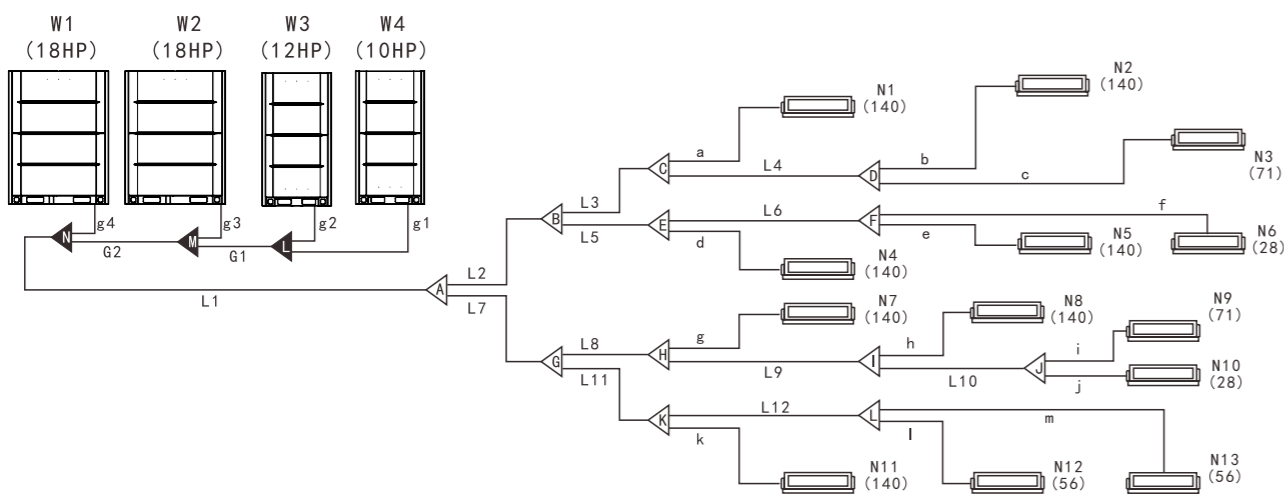

Pipe dimension of indoor unit(NO.: a,b,c,d,... m)

Indoor Unit Model	Gas side	Liquid side
Capacity: 1800~2200W	φ9.52(flared nut)	φ6.35(flared nut)
Capacity: 2800~5600W	φ12.7(flared nut)	φ6.35(flared nut)
Capacity: 6300~14000W	φ15.9(flared nut)	φ9.52(flared nut)

IDU main piping and branch pipe assembly(Number: L2,L3,L4...L12,A,B,C...L)

Capacity of downstream Indoor unit A(×100w)	Dimension of Master pipe (Gas/Liquid)	Applicable brance pipe (Gas/Liquid)	A(×100w)	Dimension of master pipe (Gas/Liquid)	Applicable brance pipe (Gas/Liquid)
A<63	φ12.7/φ6.35	BY06(L01/L01)	63≤A<168	φ15.9/φ9.52	BY07(L02/L01)
168≤A<224	φ19.1/φ9.5	BY07(L02/L01)	224≤A<330	φ22.2/φ12.7	BY01(G01/L01)
330≤A<470	φ25.4/φ12.7	BY01(G01/L01)	470≤A<710	φ28.6/φ15.9	BY03(G02/L02)
710≤A<1040	φ31.8/φ19.1	BY03(G02/L02)	1040≤A<1540	φ38.1/φ19.1	BY04(G03/L02)
1540≤A<1800	φ41.2/φ22.2	BY05(G04/L02)	1800≤A<2500	φ44.5/φ25.4	BY05(G04/L03)
2500≤A	φ54.0/φ28.6	BY08(G05/G02)			

Diameter of outer connecting pipe

ODU stop valve port diameter(Number: g1,g2,g3,g4)

Model	Gas	Liquid
NV6-252(280/335/400)T3/R1-ODU	φ25.4 (welding)	φ12.7 (welding)
NV6-450(504/560/615/680)T3/R1-ODU	φ28.6 (welding)	φ15.8 (welding)
NV6-730(785/850/900)T3/R1-ODU	φ31.8 (welding)	φ19.1 (welding)
NV6-950(1000)T3/R1-ODU	φ34.9 (welding)	φ19.1 (welding)

ODU Main pipe and branch pipes

Capacity of Outdoor unit	Main equivalent length of all piping less than 90m		Main equivalent pipe length more than 90m	
	Gas pipe/Liquid pipe	First branch of indoor unit (Gas side/Liquid side)	Gas pipe/Liquid pipe	First branch of indoor unit (Gas side/Liquid side)
8~12HP	φ25.4/φ12.7	BY01 Prats (G01/L01)	φ28.6/φ12.7	BY02 Prats (G02/L01)
14~16HP	φ28.6/φ12.7	BY02 Prats (G02/L01)	φ28.6/φ15.9	BY03 Prats (G02/L02)
18~24HP	φ28.6/φ15.9	BY03 Prats (G02/L02)	φ31.8/φ19.1	BY03 Prats (G02/L02)
26~32HP	φ31.8/φ19.1	BY03 Prats (G02/L02)	φ34.9/φ19.1	BY04 Prats (G03/L02)
34~36HP	φ34.9/φ19.1	BY04 Prats (G03/L02)	φ38.1/φ22.2	BY04 Prats (G03/L02)
38~42HP	φ34.9/φ19.1	BY04 Prats (G03/L02)	φ38.1/φ22.2	BY04 Prats (G03/L02)
44~48HP	φ38.1/φ19.1	BY04 Prats (G03/L02)	φ41.2/φ22.2	BY05 Prats (G04/L03)
50~54HP	φ38.1/φ19.1	BY04 Prats (G03/L02)	φ41.2/φ22.2	BY05 Prats (G04/L03)
56~66HP	φ41.2/φ22.2	BY05 Prats (G04/L03)	φ44.5/φ22.2	BY05 Prats (G04/L03)
68~72HP	φ41.2/φ22.2	BY05 Prats (G04/L03)	φ44.5/φ25.4	BY05 Prats (G04/L03)
74~84HP	φ44.5/φ22.2	BY05 Prats (G04/L03)	φ50.8/φ25.4	BY08 Prats (G05/G02)
86~96HP	φ50.8/φ25.4	BY08 Prats (G05/G02)	φ54.0/φ28.6	BY08 Prats (G05/G02)
98~108HP	φ54.0/φ28.6	BY08 Prats (G05/G02)	φ63.0/φ28.6	BY08 Prats (G05/G02)

Remark:

- Please select the main pipe diameter of the outdoor unit follow the above table. If the main pipe is larger, choose the main pipe according to larger one.
- If the system is more than 108HP, please consult technical personnel.



Electrical system and installation

Electrical wiring precautions

- Please design the dedicated power supply for IDU and ODU separately.
- The power supply should be equipped with a leakage protector and a manual switch.
- The power supply, leakage protector and manual switch of the IDU connected to the same ODU are required to be universal. (Please use the same circuit for the IDU power supply of the same system. And it must be turned on and off at the same time, otherwise it will seriously affect the service life of the system, and unpredictable situations may occur.)
- Please integrate the IDU and ODU connection wiring system and refrigerant piping system into the same system.
- In order to reduce interference, it is recommended to use two-core shielded cables for the signal cables of the IDU and ODU. Please do not use multi-core cables without shielding.
- During installation, the communication line and the power line must not be intertwined, and must be routed separately, and the minimum distance should be greater than 20CM, otherwise the communication of the unit may be abnormal.
- Power wiring must be entrusted to professional electricians.

ODU power wiring

Model	Power supply	Minimum wire diameter current (A)	Copper core PVC insulated wire BVV(mm ²)	Copper core XLPE insulated wire YJV(mm ²)	Manual switch (A) capacity	Leakage protector
NV6-252T3/R1-ODU	380V 3N ~ 50Hz	19.5	4.0X5	4.0X5	32	< 100mA 0.1sec
NV6-280T3/R1-ODU	380V 3N ~ 50Hz	21.6	4.0X5	4.0X5	32	
NV6-335T3/R1-ODU	380V 3N ~ 50Hz	24.9	6.0X5	4.0X5	32	
NV6-400T3/R1-ODU	380V 3N ~ 50Hz	26.5	6.0X5	4.0X5	32	
NV6-450T3/R1-ODU	380V 3N ~ 50Hz	32.2	10.0X5	6.0X5	40	
NV6-504T3/R1-ODU	380V 3N ~ 50Hz	34.0	10.0X5	6.0X5	40	
NV6-560T3/R1-ODU	380V 3N ~ 50Hz	41.8	16.0X5	10.0X5	50	
NV6-615T3/R1-ODU	380V 3N ~ 50Hz	42.9	16.0X5	10.0X5	50	
NV6-680T3/R1-ODU	380V 3N ~ 50Hz	45.5	16.0X5	10.0X5	50	
NV6-730T3/R1-ODU	380V 3N ~ 50Hz	46.0	16.0X5	10.0X5	50	
NV6-785T3/R1-ODU	380V 3N ~ 50Hz	48.0	16.0X5	10.0X5	50	
NV6-850T3/R1-ODU	380V 3N ~ 50Hz	56.8	25.0X3+16.0X2	16.0X5	63	
NV6-900T3/R1-ODU	380V 3N ~ 50Hz	57.0	25.0X3+16.0X2	16.0X5	63	

Remark: 1.The wire diameter and continuous length in the table are applicable to a maximum distance of 20 meters. If the power wiring exceeds 20 meters and the voltage drop exceeds the range of 2%, please choose a wire diameter with a larger cross-sectional area.
2.The selection of the power cord is based on the ambient temperature of 40°C.
3.The wire current carrying capacity in the attached table is only for the user's reference. The actual interception capacity of the wire varies depending on the type and length of the cable, the way of pipe penetration, and the actual laying environment, and the correction factor is different.

ODU power connection

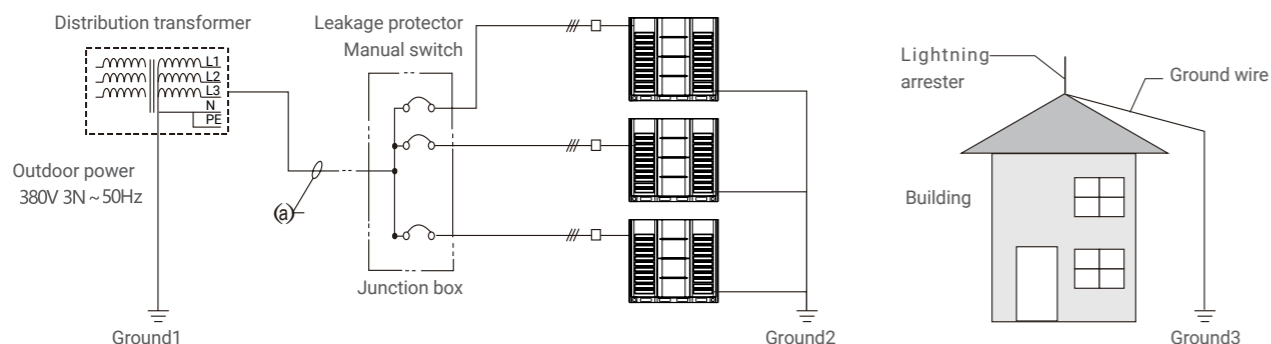

IDU power wiring

Model	Power supply	Minimum wire diameter(mm ²)			Manual switch		Leakage protector	
		Dimensions (Continuous Length)	Dimensions (Continuous Length)	Ground wire	Capacity	Fuse		
All IDU Model	90-140Q8 125-140F2 125-140F5	380V ~ 3N50Hz	2.5 (30m)	4.0 (50m)	φ1.6mm	30	15	20A, 30mA < 0.1sec
	Other model							

Remarks: The wiring diameter and continuous length in the table indicate that the voltage drop is within 2%. When the continuous wiring length exceeds the value in the table, please follow the relevant regulations to select the wire diameter.

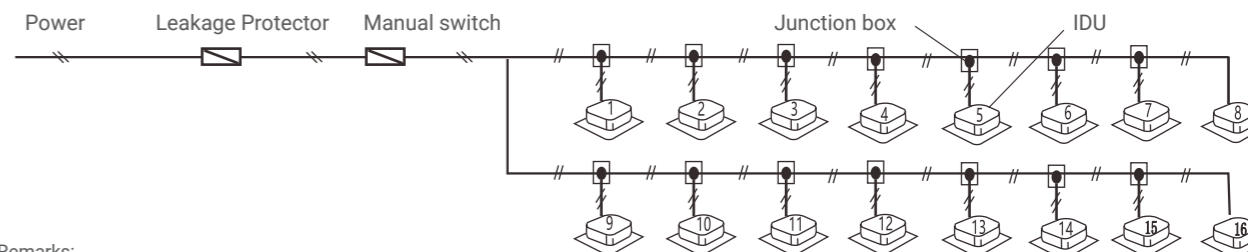

Remarks:

1. Please use the refrigerant piping system, the indoor unit-indoor unit room, and the indoor unit-outdoor unit connection signal line as the same system.
2. All the internal units in the same system must be powered in a unified manner, and some internal units cannot be cut off, otherwise the unit will fail.
3. When the power cable and the signal cable are parallel, please put the wires into their respective wire ducts, and leave a suitable distance between the wires. (Distance between power cables: 300mm below 10A, 500mm below 50A)
4. When multiple outdoor units are connected in parallel, the main outdoor unit must be set. (Refer to the settings of the DIP switch)

Control system and installation

- Signal lines must be shielded. Using other wires may cause signal interference and cause malfunction.
- The shielding nets of all shielded wires are connected to each other and finally connected to the sheet metal ground at one point.
- It is forbidden to bundle signal wires, refrigerant pipes, power wires, etc. together. When the power line and the signal line are laid in parallel, they should be kept at a distance of more than 300mm to prevent the signal source from being disturbed.
- Signal lines cannot form a closed loop.
- The signal line has no polarity, and there is no need to distinguish it when wiring.

IDU and ODU signal line wiring

- Please use two-core shielded wire (≥0.75mm²) for the signal cable of indoor and outdoor units, without polarity. The signal cable of indoor and outdoor units should be connected as far as possible from the end of the outdoor unit.

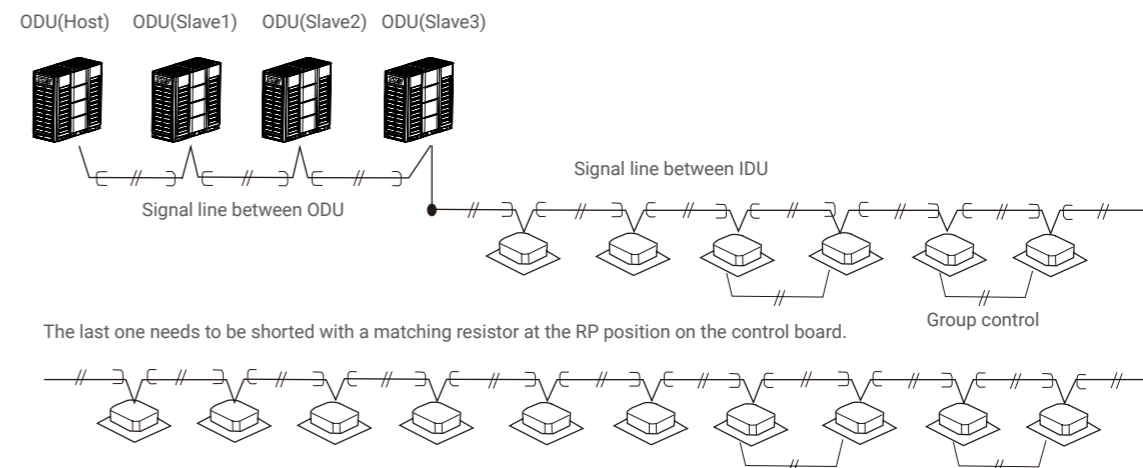

Certificates

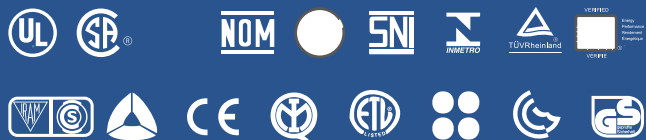

ISO 9001:2015

ISO 14001:2015

ISO 45001:2018

TECHNICAL SUPPORT

JSC Baltic Refrigeration Group

Address: S. Zukausko str. 11, Ramučiai, Kaunas district, Lithuania

Web: brgroup.eu E-mail: info@brgroup.eu Tel. nr. +370 37 373248

nordis-ac.com